



air
cadets

the next generation

air cadet publication

ACP 33

flight

volume 2 - principles of flight

Amendment List		Amended by	Date Incorporated
No	Date		
1			
2			
3			
4			
5			
6			
7			
8			
9			
10			
11			
12			
13			
14			
15			
16			

ACP 33 FLIGHT

CONTENTS

Volume 1 History of Flight

Volume 2 Principles of Flight

Volume 3 Propulsion

Volume 4 Airframes

Volume 2

Principles of Flight

Chapter 1 Lift and Weight.

Chapter 2 Thrust and Drag.

Chapter 3 Stability and Control.

Chapter 4 Stalling.

Chapter 5 Gliding.

Chapter 6 The Helicopter.

Instructors' Guide

CHAPTER 1

LIFT AND WEIGHT

Introduction

1. In this chapter we shall look at how an aircraft, which is much heavier than the air in which it flies, is nevertheless supported by that air.

Newton's 3rd Law

2. Sir Isaac Newton, many years ago formulated laws which explain the way things move. One of his laws states that "to every action, there is an equal and opposite reaction". So how does this apply to everyday objects such as cars, boats and aircraft? Imagine a car weighing, say, 1 tonne parked on the road. The car's weight presses down on the road with a force of 1 tonne - and from Newton's law we know that to support the car, the road must press up with a force of 1 tonne. Similarly a boat weighing, say, 10 tonnes is supported by an upward force (from the water) of 10 tonnes - otherwise it would sink! The same must apply to an aircraft in flight. But how can an aircraft, which might weigh many tonnes be supported by such a flimsy substance as air? The clue is in the fact that whereas cars and boats are supported by the road (or water) when in motion and also when they are stationary, an aircraft can only stay airborne as long as it moves (except for the Harrier of course).

Air is a Substance

Air is a substance

3. The fact that air really is a substance is not immediately obvious, especially indoors where the air is still; but outside you can see smoke being blown sideways from chimneys, and branches of trees swaying in the wind. In a gale you may even find difficulty in walking - branches may be broken from the trees, or slates ripped from roofs. In hurricanes, whole trees are torn up by the roots and houses are destroyed like matchwood. Obviously, moving air exerts forces on objects- and the greater its speed, the greater the forces it exerts. Air is undoubtedly a very real substance, invisible as it is.

Moving Objects Through The Air

4. The force exerted on stationary objects by the movement of air is one thing, but what happens if the air is still and an object moves through it? Imagine cycling

along a flat road on a perfectly calm day. As your speed increases, you will be able to feel the air against your face and your hair will be blown back and your eyes may even start to water. The faster you pedal, the greater the force of this apparent wind.

5. Clearly, whether you have air moving past a stationary object, or an object moving through stationary air, similar forces are experienced.

Weight

Every object has weight

6. If you lift a chair in one hand and hold it still at almost arm's length, you will feel the upward force needed to balance the downward force of gravity acting on the chair (the weight of the chair). Less effort from your muscles (less lift) makes the chair sink, more effort from your muscles (more lift) and the chair will rise. How is this lifting force to be given to an aircraft?

7. Try holding two sheets of A4 paper with the edges vertical and about one finger's width apart. You would imagine that by blowing hard down the gap between the two papers they would be blown apart.

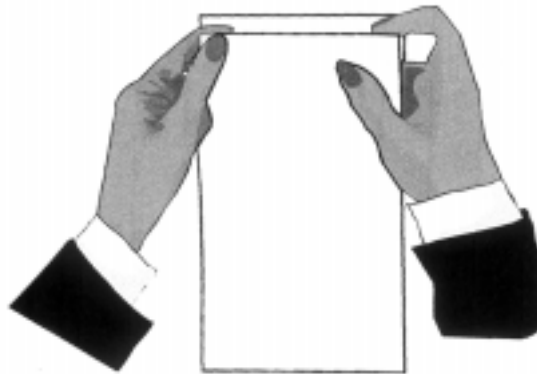

Fig 1-1 Holding the sheets



Fig 1-2 The sheets are drawn together

The opposite happens! The harder you blow, the more firmly the papers are drawn together! Similar effects can be seen in everyday life - a slightly open door closing rather than opening when a draught blows through the gap, and canal barges drawn together when they pass each other. What causes these things to happen? To find out we use a wind tunnel to experiment.

Wind Tunnel Tests

8. If air is flowing past a stationary object it will have the same effect as if the object were moving through the air. Wind tunnel tests on stationary models will, therefore, reproduce effects similar to those experienced in flight.

Fig 1-3 Air flowing through a constricted tube

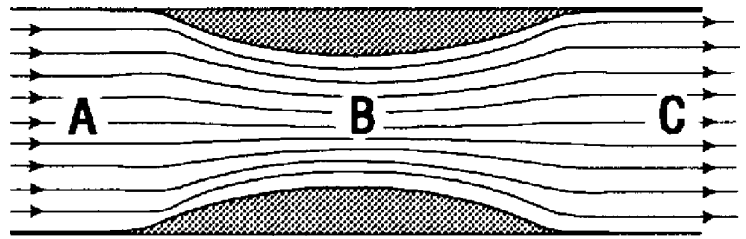

In the simple experiment, air is blown through a tunnel which has a constriction in the middle (that is, it becomes narrow). The air goes in at point “A”, passes the constriction at point “B”, and comes out at point “C”. Both the speed and the pressure of the air are measured at points “A”, “B” and “C”.

Changes in speed

9. As there is no way that air can be stored in the constriction, the amount of air leaving the tunnel must be the same as the amount of air entering it. Therefore, the air must speed up to pass through the narrowest point. That is, as the air moves from “A” to “B” its speed increases, reaching a maximum at “B”. Moving from “B” to “C” the speed decreases, eventually returning to the same speed as before. These speed changes have an effect on the pressure of the air in the airflow, and that effect is governed by Bernoulli’s Principle. This is a fairly complicated physical law, but all we need to know about it here is that when air is moving in a streamlined flow (i.e. smooth and not turbulent), in areas where the airspeed increases, the air pressure decreases; and conversely, where the airspeed decreases, the air pressure increases. In our experiment, this means that the pressure recorded at “B” will be lower than at “A” and “C”. If you think back to your experiment with the two pieces of paper, when you blow between the papers, the speed of the air between the sheets causes its pressure to drop, which allows the pressure on the outside to push the sheets together. Can you now explain why two canal barges are drawn together when they pass, travelling in opposite directions? Hint: Bernoulli’s principle is true for all fluids (i.e. water and air).

Bernoulli’s Principles

Proving The Theory

10. Hold a half sheet of A4 (halved lengthwise), such that the end between your fingers is horizontal, but allow the rest of the paper to curve downwards under its own weight. Then blow along the curved top of the paper only; it will rise into line with the airflow. By speeding up the air over the top you have reduced the pressure above the paper, so the air pressure under the paper pushes it up.

Fig 1-4 The paper rises



The harder you blow the more it will rise. The top surface of an aircraft wing behaves in a similar manner.

Lift

w

11. The top surface of an aircraft's wing is shaped such that air which flows between it and the undisturbed air a little way above the wing is, in effect, being forced through a constriction.

Fig 1-5 Air flowing over a wing

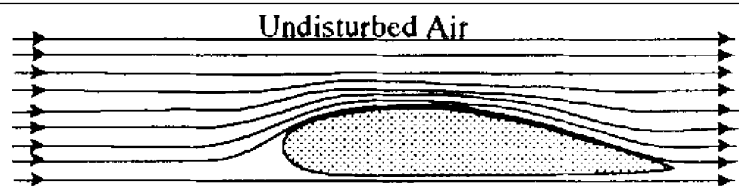

Thus the air flows over the wing at an increased speed - and therefore at a reduced pressure - compared with the surrounding atmosphere. The resulting pressure difference between the air above and below the wing tends to lift it up. This pressure difference is however not the only thing that contributes to lift. In real life, the airflow rarely approaches a wing as shown above.

In most flight conditions, the wing is inclined to the airflow at a slight positive angle so that it deflects some of the airflow downwards.

Fig 1-6 Air flowing around a wing

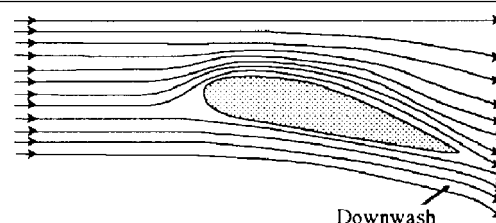

This production of “downwash” results in an upward force which adds to the lift needed to hold up the aircraft in flight, though not normally as much as the lift generated by the top surface of the wing.

Distribution of lift

How lift acts on a wing

12. The whole surface of a wing, both top and bottom, is affected by the airflow. In other words, there are pressure forces acting all over the wing - and it follows that there can be lift forces all over the wing. The arrows on the diagram show how the lift forces might appear on a typical wing in normal level flight.

Fig 1-7 Lift distribution round a wing

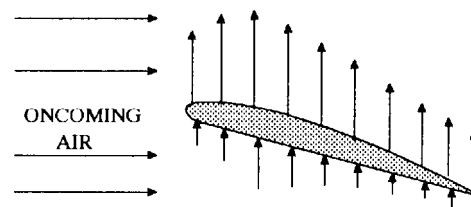

The length of each arrow indicates the amount of lift at that point on the wing's surface. Note that:

- a. Lift is not distributed evenly around the wing.
- b. The top surface normally generates more lift than the bottom surface - at some angles of attack, as much as 80% of the total! (see para 14b)
- c. The greatest amount of lift on the top surface occurs where the surface is curved the most.
- d. The greatest effect, on both top and bottom surfaces, is nearer the front edge of the wing than the rear (that is, about 1/3 of the way from the front).

e. All lift forces act at 90° to the direction of the airflow - which is the same as the flight path of the aircraft.

Centre of Pressure

Centre of Pressure

13. Rather than deal with the thousands of small lift forces spread over the wing surfaces, we normally add them together and represent them by a single straight line. This single line is drawn from the point at which all the forces balance. This is the point at which all the lift can be said to act and it is called the “centre of pressure”.

Centre of Gravity

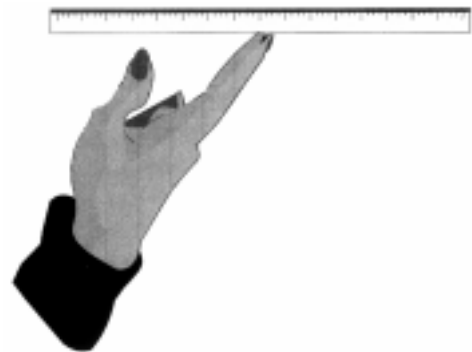

Fig 1-8 Centre of gravity

This idea is very similar to finding the centre of gravity of a ruler by balancing it on your finger. All the small forces of gravity acting on the ruler balance about the centre of gravity.

How Lift Varies

Factors affecting Lift

14. Several factors affect the amount of lift produced by a wing. Those you need to know about at this stage are:

a. Airspeed. Altering the airspeed will vary the amount of lift produced by the wings. When an aircraft is stationary before take-off the wings are producing no lift. However, as the aircraft accelerates along the runway, the lift increases until there is enough to take the weight of the aircraft off the ground. In normal flight the pilot can either use the throttle, or make the aircraft climb or dive to alter the speed of the aircraft through the air. You might think that by doubling the airspeed there would be twice the lift, but in fact lift increases as the square of the speed. Double the airspeed gives four times the lift; treble the airspeed gives nine times the lift, and so on.

Parts of a wing

b. Angle of Attack. In most flight conditions the wings meet oncoming air at a slight angle which is called the angle of attack. This is the angle between the chord line of the wing and the oncoming air (or path of the aircraft).

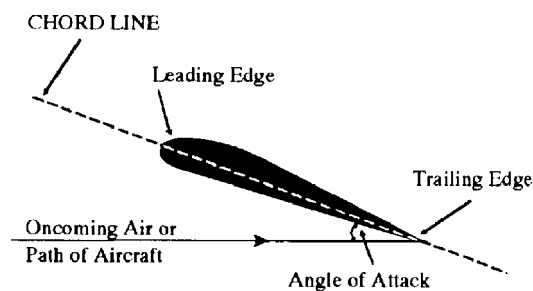
Fig 1-9 Angle of attack

The chord line is a straight line joining the leading edge to the trailing edge. The pilot can alter the angle of attack by altering the pitch attitude of the aircraft - which the pilot does by easing forward or pulling back on the control column. If the angle of attack is increased steadily from 0° and the airspeed is kept constant, the amount of lift will increase until the angle reaches about 15° . If the angle of attack is increased beyond this point, the lift rapidly decreases and the wing is stalled, a condition which is described later.

c. Air Density. If the air becomes "thinner" or less dense (and this can happen with increases of height, temperature or humidity), the amount of lift is reduced. A low air density will directly concern a pilot, as on take-off the pilot would have to compensate for the reduced lift, by reaching a higher speed than usual to become airborne. This means the pilot would need more runway - and there might not be enough! To calculate the take-off run the pilot would use tables which allow for engine performance, the weight of the aircraft, the wind speed and direction, and of course the air temperature, humidity and density. The pilot might even have to postpone a take-off or alter something to put the aircraft within a safe limit for take-off: for example, off-load some cargo.

d. Wing Shape and Area. The remaining factors that affect the amount of lift produced are the shape of the wing section and the plan area of the wing, both of which have been calculated by the aircraft designer to suit the aircraft's role and required performance. Some different types of wing section are shown in the diagram. A high-lift section would be used where good lift at low speeds is all-important - for example on a sailplane.

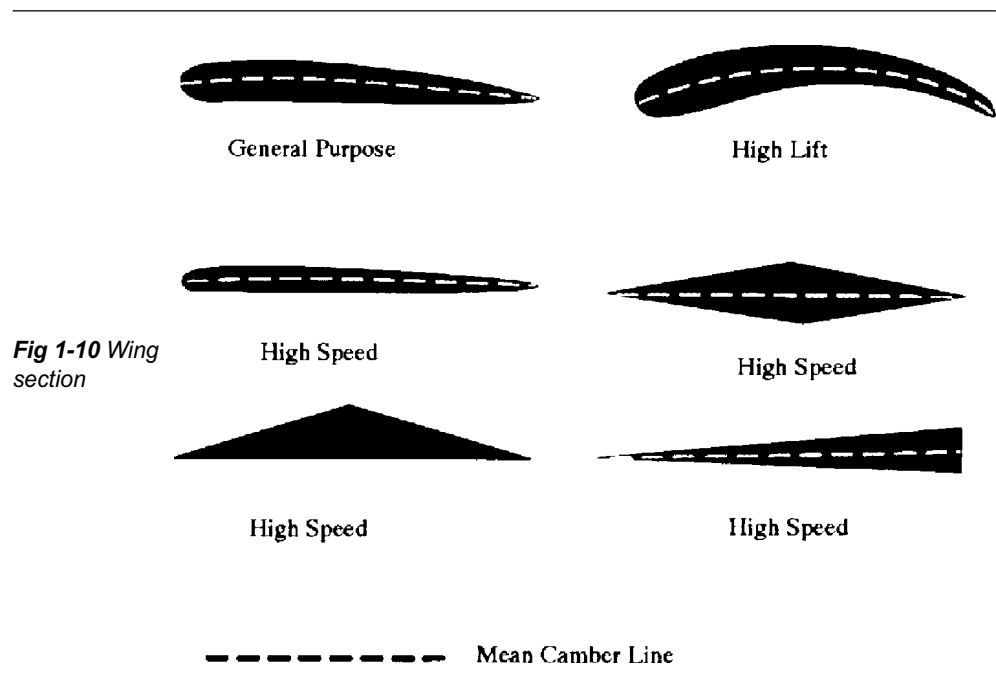

Fig 1-10 Wing section

A general purpose section would suit a moderately fast aircraft, as long as it was not intended to approach the speed of sound. And a high-speed section would be used for supersonic aircraft. You can see from that a high-lift wing has a lot of “camber” (or curvature), which means that even at low airspeeds the air passing over the wing has to speed up a lot, thus generating high lift. However, at very high airspeeds, pronounced camber causes some unwanted effects (such as shock-waves), so the designer chooses a thinner wing section with not much camber. Such a wing will produce little lift at low airspeeds, which is why high-speed aircraft have very high take-off and landing speeds. More lift for any given wing section and airspeed can be found by increasing the plan area of the wing - that is, by making the wing bigger. But a bigger wing is heavier and also more resistant to rapid manoeuvres, hence it would not be acceptable in, for example an air combat aircraft. So the designer chooses a wing area to suit the role - a big wing for heavy slow transport aircraft, for instance. In the finished aircraft, depending on the design the pilot may have varying amounts of control over the wing section and area. For example, the hinged flaps fitted to most light aircraft have the effect of increasing the camber of the wing when they are lowered. More advanced Fowler flaps slide backwards to increase the wing area, as well as hinging downwards.

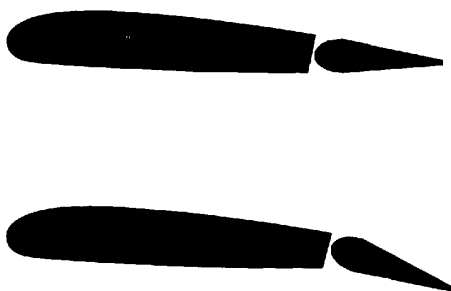

Fig 1-11 Hinged flap increases camber



Fig 1-12 Fowler flap increases camber and wing area

Lift and Weight in Straight and Level Flight

Lift and Weight

15. In steady straight and level flight, the lift force equals the force of gravity acting on the aircraft (its weight). If the lift is greater than the weight, an aircraft will climb; and if the weight is more than the lift, it will descend.

Fig 1-13 Lift against weight

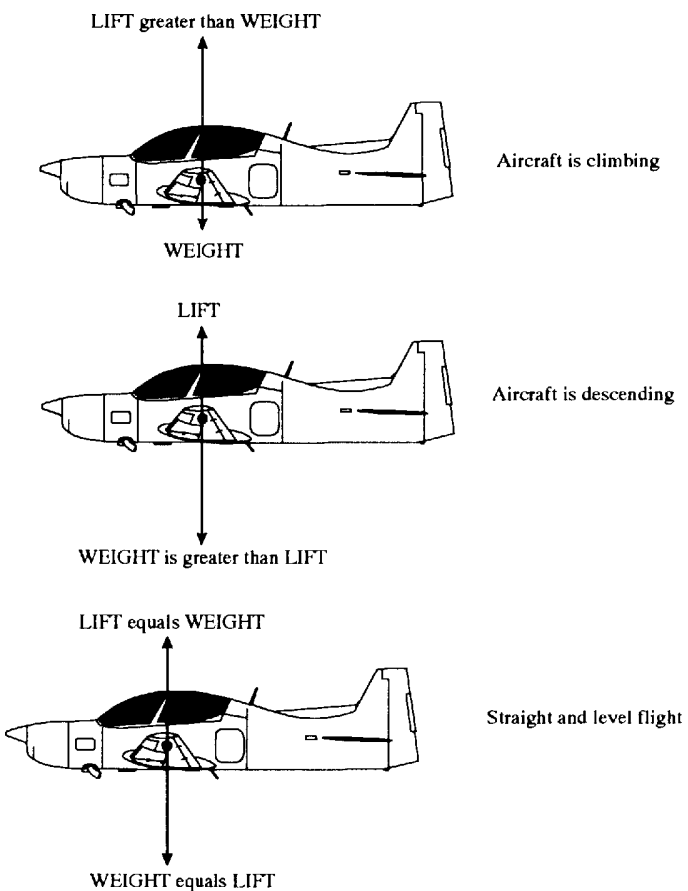

Self Assessment Questions

Do not mark the paper in any way - write your answers on a separate piece of paper.

1. Newton's 3rd law states.

- a. Every action has an equal and opposite reaction.
- b. Every object has weight. c .
- Weight equals Lift during flight. d .
- Every force causes an object to move.

2. What has happened to the air pressure at point "B".

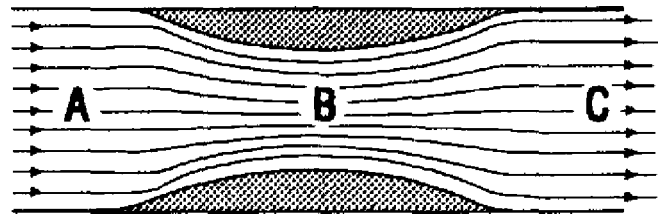

- a. It is greater than at point A. b. It is
- lower than at point A. c. It is
- greater than at point C. d. It is the
- same as point C

3. In what direction does lift operate relative to airflow.

- a. Parallel to it. b .
- Perpendicular (at 90°) to it. c .
- Straight up. d .
- Straight down.

4. Which letter in the diagram represents the angle of attack.

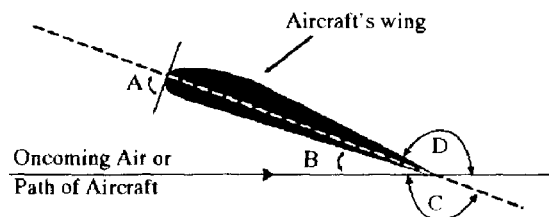

CHAPTER 2

THRUST AND DRAG

Introduction

1. Besides the forces, lift and weight, which act on an aircraft in flight, there are two other forces to consider - thrust and drag.

Thrust

Thrust and Drag

2. We have already seen that to generate lift, which is needed to oppose the weight of the aircraft and keep it in the air, the wings of an aircraft must have air flowing over them. This airflow is in turn produced by “thrusting” the aircraft forwards through the air - and of course it is the job of the aircraft’s engine (or engines) to provide the necessary force (called “thrust”). The engine does this by throwing air backwards, either by having a propeller which “screws” the air backwards or by expelling air from the rear in the case of a jet engine. In both cases, throwing the air backwards thrusts the aircraft forward (Newton’s law about every action having an equal and opposite reaction). The thrust force acts approximately along a line drawn from the tail to the nose of the aircraft, and its size depends upon the amount of engine power selected by the pilot.

Drag

3. Anyone who has a bicycle will know that the faster you go, the more air resistance you encounter. The force which hinders your progress is called “drag”. The same thing happens when an aircraft is thrust through the air. The wings, fuselage, tail unit, undercarriage, engines, aerals - in fact every part of the aircraft over which the air flows - produces drag which resists forward motion. If all these drag forces are added together and are represented by a single line (as we did for the lift forces when discussing the centre of pressure), the line would run approximately from the nose to the tail of the aircraft, directly opposing the thrust. Thus, the more drag there is, the more thrust is needed to overcome it. More thrust needs more engine power, which means a bigger engine, more fuel, more weight, more expense, more everything! It is the designer’s job to make the aircraft fly at the best possible speed for the thrust available. The more the designer can reduce

the drag, the more efficient and economical the aircraft will be. So what causes drag and how can it be reduced to a minimum?

What causes drag?

4. A great deal of drag is caused by the shape or “form” of all the parts of the aircraft. When any object moves through the air it is accompanied by a “wake” of complicated eddies and vortices, as can be seen when a hand is passed through a cloud of smoke. In flight, engine power which could have been used for the forward movement of the aircraft is wasted in stirring up these vortices - and the bigger the wake that they form, the more wasted energy (and hence the more drag) there is. An extreme example is a flat plate in an airflow; its drag will be greatest when the plate is at 90° to the airflow, and least when it is parallel to the airflow.

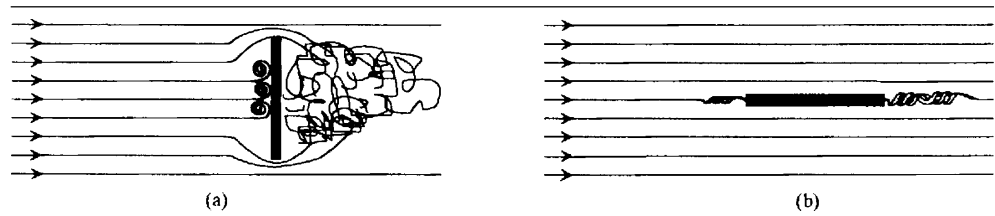

Fig 2-1 Flat plate: a) at 90° to the airflow
b) parallel to the airflow

5. Drag can be minimized by:
- a. Not building in drag at the design stage - that is, by eliminating as many protruding external parts as possible.



Fig 2-2 Bags of Drag!!

FIG 2-3 *That's better!*

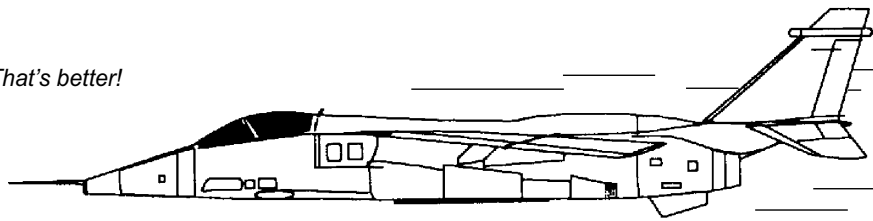

b. Streamlining and “fairing off” all the parts of the aircraft which remain in the airflow, thus making the air flow as smoothly as possible, to reduce the size of the wake. The effective use of streamlining in reducing drag can be seen from the wind tunnel experiments shown in the diagram below. The drag on a flat plate can be reduced to 5% (1/20 th) of the original by efficient streamlining.

Fig 2-4 *The effects of streamlining*

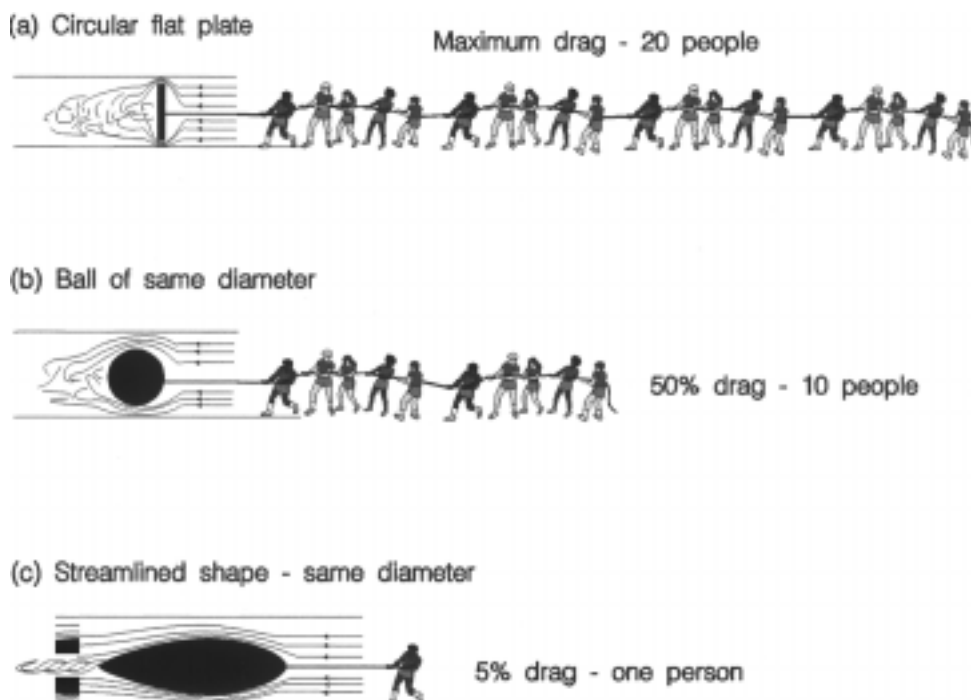

Fineness ratio

c. Designing the streamline shapes to have a “fineness ratio” of between 3 and 4 to 1 (the fineness ratio being length compared to breadth, in order to reduce the size of the wake to a minimum.

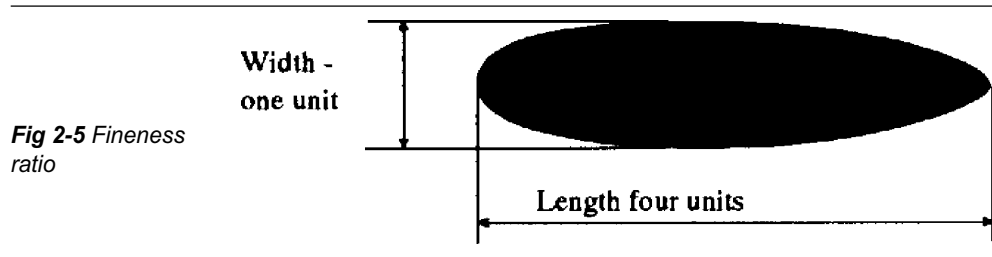

Fig 2-5 Fineness ratio

Variation of Drag with Airspeed

Airspeed and Drag

6. The amount of drag varies with the square of the airspeed - that is, at twice the airspeed there is 4 times as much drag; at 3 times the airspeed, 9 times the drag; and so on.

Thrust and Total Drag in Straight and Level Flight

Thrust = Drag

7. In steady (i.e. unaccelerated) straight and level flight, just as lift must equal weight so that the aircraft neither climbs nor descends, so the thrust must equal the total drag. If the thrust is greater than the total drag, the aircraft will gather speed. If the total drag exceeds the thrust, the aircraft will slow down.

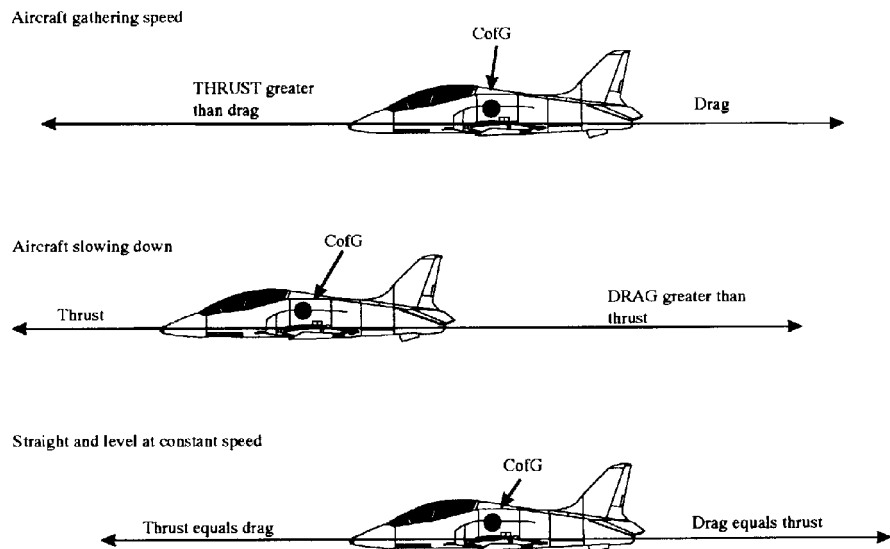

Fig 2-6 The battle between thrust and drag

In steady straight and level flight, the thrust equals the total drag. This point is not always easy to understand and at first it may be thought that if the thrust equals the total drag an aircraft must be stationary! But if an aircraft were stationary there would be no drag! A comparison may help you understand. If you pedal a cycle on a level road at a constant 15 kph, the propelling force you produce is a steady thrust exactly equalling the drag of machine and rider through the air plus the friction on bearings and tyres. If you increase your pedalling effort (or thrust), at first you will gather speed. As your speed increases, the drag of the wind and friction will also increase, until it equals your new pedalling force. You will then stay at a new constant speed, say 20 kph, with steady thrust equalling steady drag. If your pedalling force is reduced (less thrust) or a head wind arises (more drag) the cycle will slow down until it is at a new constant speed where the drag and thrust are once again equal.

The Aircraft in Balance

4 forces in balance

8. To summarise: in straight and level flight at constant speed, two pairs of forces act on the aircraft. The thrust opposes the drag and is equal to it and the lift equally opposes the weight.

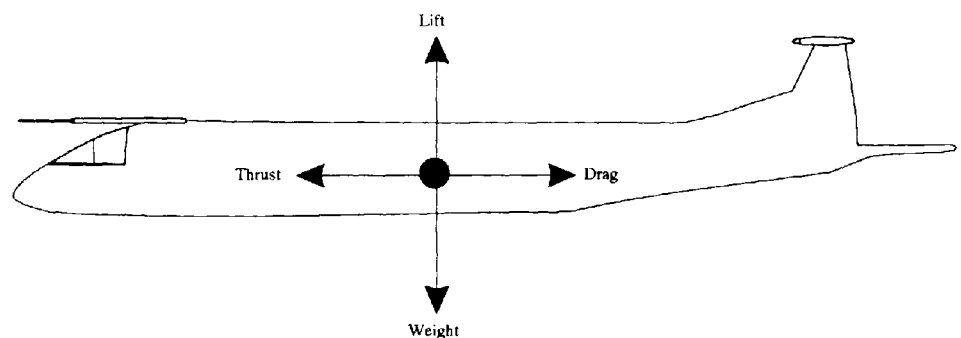

Fig 2-7 Aircraft forces in balance

Self Assessment Questions

Do not mark the paper in any way - write your answers on a separate piece of paper.

1. What is the force called that drives an aircraft forwards?
 - a. Lift.
 - b. Weight.
 - c. Thrust.
 - d. Drag.

2. What is the force called that resists the forward motion of an aircraft?
 - a. Lift.
 - b. Weight.
 - c. Thrust.
 - d. Drag.

3. If you doubled the airspeed the drag would increase by a factor of :
 - a. 2
 - b. 4
 - c. 6
 - d. 8

4. If thrust equals total drag and lift equals weight then the aircraft is most probably:
 - a. Climbing rapidly.
 - b. Flying straight and level while accelerating at a constant rate.
 - c. Flying straight and level at constant speed.
 - d. Descending slowly

CHAPTER 3

STABILITY AND CONTROL

Stability

1. Planes and Axes. We will now look at the terms used to describe the movement of an aircraft in 3 dimensions. Note that for now we are thinking of movement of the aircraft relative to itself - changes of its attitude - rather than it travelling through the air. Firstly, there are 3 axes about which an aircraft rotates; they all go through the centre of gravity, and they are all at 90° to each other. Similarly, there are 3 planes in which the aircraft moves (a plane in this sense is just a flat sheet or area).

3 Planes of movement

3 Axes

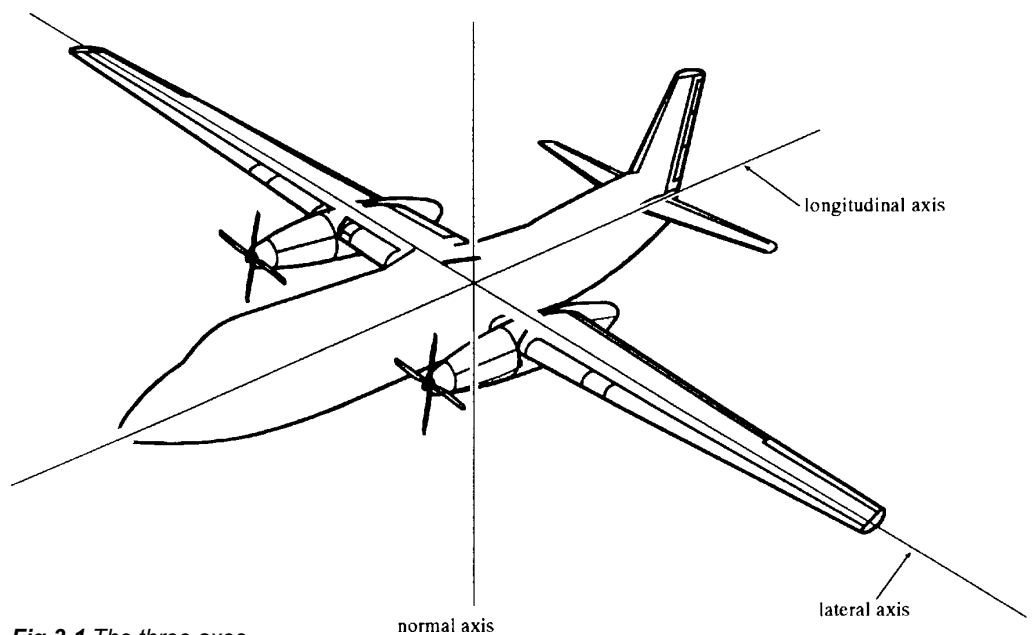

Fig 3-1 The three axes

When an aircraft moves in one plane it rotates about an axis, and vice-versa. It can move in one, 2 or all 3 planes at the same time. The relationship between the planes and the axes are that the aircraft:

- a) Moves in the pitching plane (i.e. pitches) about its lateral axis
- b) Moves in the rolling plane (i.e. rolls) about its longitudinal axis
- c) Moves in the yawing plane (i.e. yaws) about its normal axis

Why Stability?

What is stability?

2. Imagine an aircraft cruising along in level flight in bumpy air (turbulence). The bumps are continually causing first one wing then the other to drop, or the nose to rise or fall. A well-designed aircraft will tend to go back to level flight of its own accord, without the pilot having to make continual adjustments. This property is called stability, and to understand it we need to consider stability in each of the 3 planes:

a) Stability in the pitching plane (Longitudinal Stability). In the diagram, (a) shows an aircraft flying at normal cruising speed.

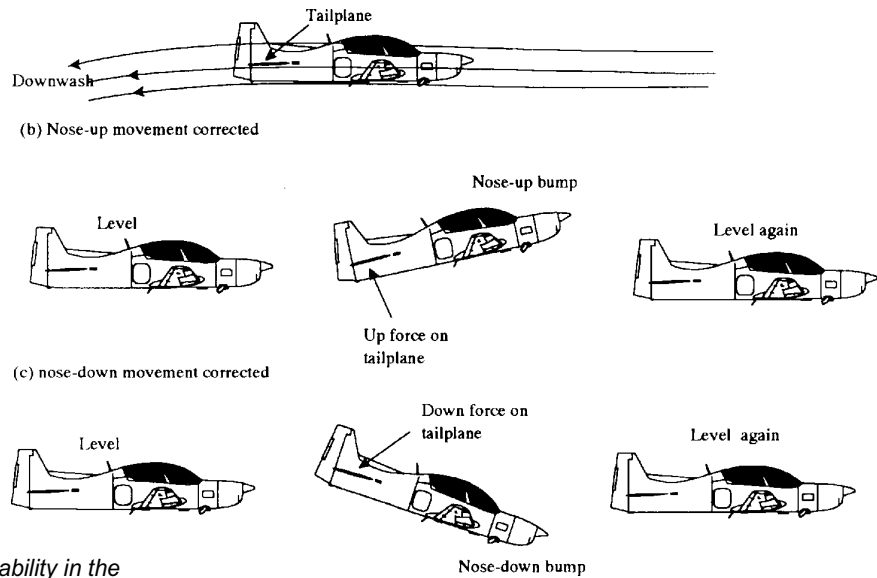

Fig 3-2 Stability in the pitching plane

As the tailplane is at the end of the fuselage, a long way from the centre of gravity, any forces on it will have great leverage. The tailplane is set to meet the local airflow at 0° angle of attack in cruising flight, and because it is cambered equally on both sides it produces no force up or down. If some disturbance, perhaps bumpy air in a cloud, jolts the aircraft into a tail-down attitude, the tailplane momentarily has an angle of attack to the oncoming air; consequently it produces lift which “levers” the aircraft back to a level position (b). If the aircraft is jolted nose down, the tailplane produces a downward force which levers the aircraft back into the level position, when once more the tailplane has no upward or downward force upon it (c). The aircraft is said to have stability in the pitching plane.

Dihedral angle

b) Stability in the Rolling Plane (Lateral Stability). The wings of most aircraft are set into the fuselage at a slight upward angle to the horizontal called the dihedral angle. All or part of the wing may be inclined in this way, with the aim of making the aircraft laterally stable. If the wing drops in turbulent air, the lift force is no longer vertical and it no longer opposes the weight fully.

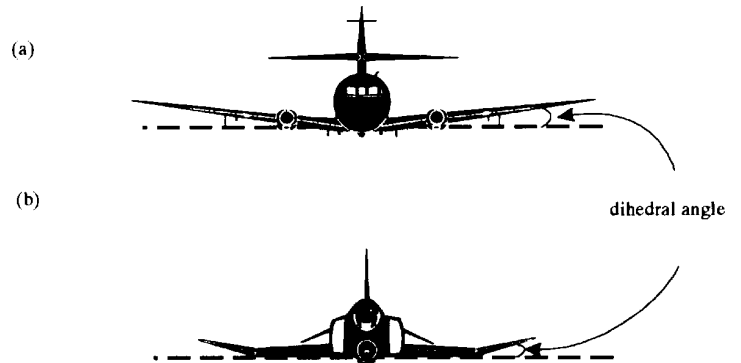
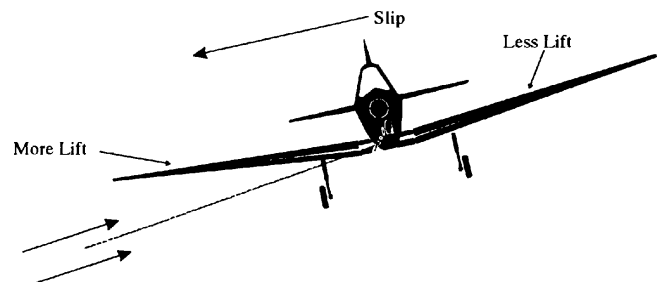

Fig 3-3 Dihedral aircraft

Consequently, the aircraft begins to slip sideways, down towards the lower wing, and a sidewind strikes it. The lower wing, because of its dihedral, meets the sidewind at an angle - an angle of attack - which is greater than that of the upper wing.

Fig 3-4 Stability in the rolling plane



The lower wing therefore produces more lift than the upper wing and rolls the aircraft back until the wings are level. Another reason why the lift on the upper wing is less than that of the lower wing, is that it is shielded by the fuselage from some of the sidewind, so not only is the angle of attack smaller on the upper wing, but also the airflow is slower. Many aircraft are designed with little or no dihedral, but they are nevertheless stable in roll because of this shielding of the upper wing.

Anhedral angle

Another stable design is the high wing aircraft, where the centre of gravity is well below the wing: here, the pendulum effect of the weight of the aircraft gives lateral stability.

Fig 3-5 Anhedral aircraft

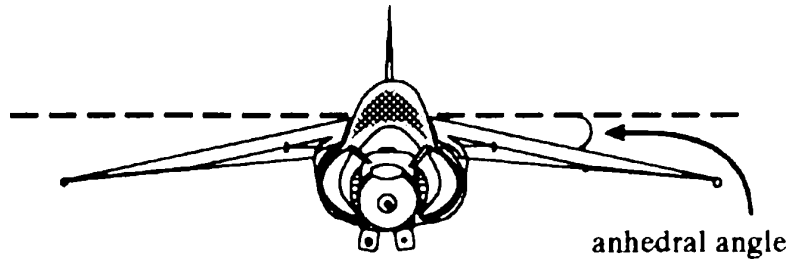

Some aircraft have quite a noticeable anhedral - wings inclined at a downward angle to the horizontal - which works on the same principle as dihedral, but with the opposite effect, creating lateral instability. This is the designer's way of reducing the excessive lateral stability which can be encountered with "swept-back" wings.

c) Stability in the Yawing Plane (Directional Stability). Should an aircraft suddenly be made to yaw to one side by an air disturbance, it continues to "crab" in its original direction, with a sidewind blowing on its fuselage and fin surfaces. This produces a sideways force which, on areas to the rear of the centre of gravity of the aircraft, will tend to yaw the aircraft back to its original heading, just like a weathercock.

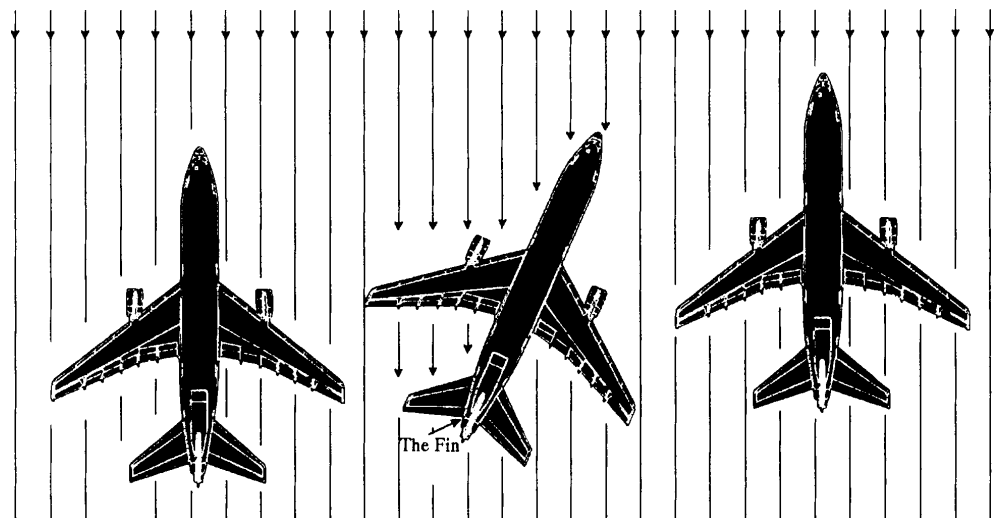

Fig 3-6 Stability in the yawing plane

Of course, the sideways force on areas ahead of the centre of gravity will have the opposite (and unwanted) effect - which is why most aircraft have a fin, placed as far back as possible, to increase the weathercock effect and ensure directional stability.

How Much Stability?

Stability and Role

3. High stability can be extremely tiring as, when manoeuvring, the pilot constantly has to overcome the stabilising forces. Conversely, too little stability will mean that the pilot has to make continual corrections to keep the aircraft on the chosen flight path. So, the designer has to strike a balance between the two extremes. The exact amount of stability to be built into the aircraft depends on its role. Normally stability will be highest for large aircraft, and least for fighters where good manoeuvrability is required.

The Pilot's Controls

Controlling an aircraft

4. So far you have learnt the basics of how an aircraft flies, and how it has built-in stability so that it will regain its balance if disturbed. Although to some extent the aircraft will fly itself, the pilot needs to manoeuvre it at will - the aircraft must not fly the pilot! The pilot will need to take-off, climb, descend, turn, complete the mission and finally land. In other words, the pilot must be given the means to control the aircraft very precisely.

3 Main Control Surfaces

5. Three main controls - elevators, ailerons and rudder - are provided, and their function is to move the aircraft about its 3 axes (lateral, longitudinal and normal). In other words, using these controls the pilot can make the aircraft:

- a). Pitch - Where the nose of the aircraft rises (pitching up) or falls (pitching down).
- b) Roll - When one wing rises while the other falls. Right wing down is rolling right.
- c) Yaw - When the nose of the aircraft moves left (left yaw) or right (right yaw).

Note in particular that we always describe pitching, rolling and yawing relative to the pilot and not to the horizon.

Which way is “up”?

6. It matters not whether the aircraft is straight and level, upside down, going vertically upwards, or whatever - if the nose pitches towards the pilot’s head it is pitching “up”, and if it pitches towards the pilot’s feet it is pitching “down”. Similarly, when we say “left yaw”, “right yaw”, “left roll”, “right roll”, we are always referring to the pilot’s left and the pilot’s right, regardless of the attitude of the aircraft.

How The Pilot Uses The Controls

Use of Elevators

7. The Pitching Plane. The pilot uses the elevators to make the aircraft’s nose pitch nose-down or nose-up. On most aircraft the elevators are two moveable parts of the tailplane, one on each side. On conventional aircraft they are hinged to the trailing edge of the tailplane where they have most leverage about the centre of gravity. They are linked to the pilot’s control column (usually called the “stick”). Moving it forward lowers the elevators, which then have an angle of attack - therefore lift - and the aircraft is levered tail up/nose - down about its lateral axis. If the pilot did this from the straight and level attitude, the aircraft would dive; if the pilot did it while in a vertical climb, the aircraft would turn towards the level position.

Fig 3-7 Position of the elevators

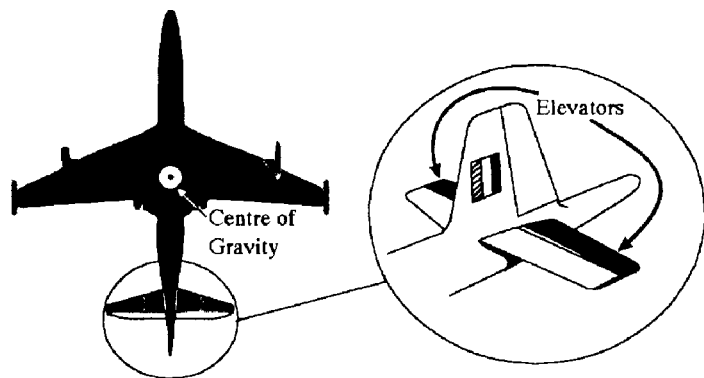

Note that pitching continues as long as the elevators are deflected, and it stops when the pilot centralises the stick, such that the elevators again lie flush with the tailplane. Moving the control column backwards of course, has the opposite effect. “Stick back, nose up”, “Stick forward, nose down” - always remembering that “up” and “down” are measured solely in relation to the pilot, and not to the world outside the aircraft.

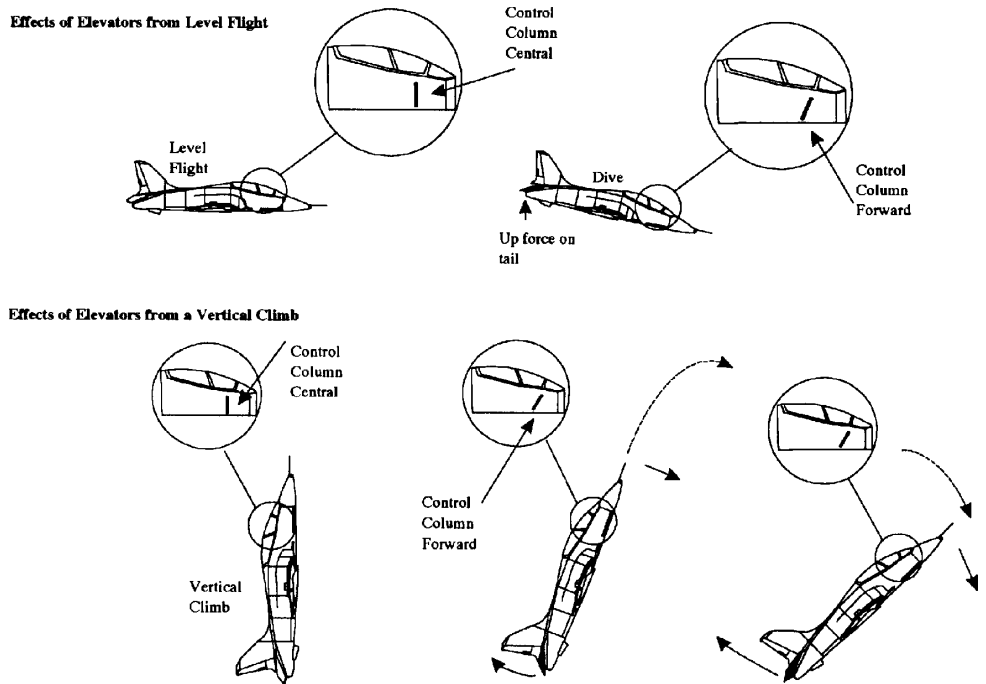

Fig 3-8 Effect of the elevators

The Rolling Plane

Use of Ailerons

8. To roll the aircraft, the pilot uses the two moveable parts of the wings called ailerons. They also are linked to the stick, and conventionally are hinged to the trailing edges of each wing near the wing tips, where they have the most leverage about the centre of gravity. By moving the stick to the left, the pilot raises the left aileron and depresses the right. The left aileron thus has a reduced angle of attack and less lift.

Fig 3-9 Position of the Ailerons

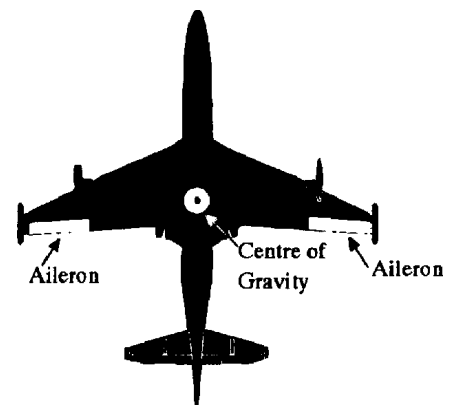
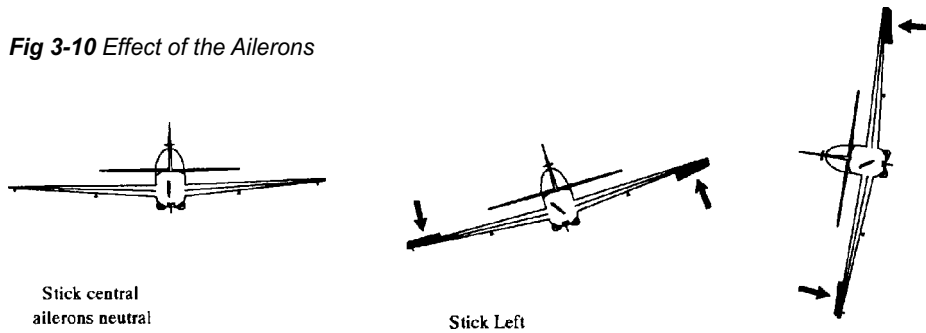

Fig 3-10 Effect of the Ailerons



The extra upward force on the right wing and the reduced upward force on the left wing rolls the aircraft to the left about its longitudinal axis. It continues to roll until the pilot returns the stick to the central position, where the ailerons are again aligned with the wings surfaces. Note that if the aircraft were climbing or diving vertically, the roll to the left would take place just the same. For a roll to the right, the stick is moved to the right; the right aileron goes up, the left aileron down. “Stick to the right, roll to the right”, “Stick to the left, roll to the left”.

The Yawing Plane

Use of Rudder

9. To move the aircraft in the yawing plane, the pilot uses the rudder, which is linked to the rudder pedals in the cockpit. On most conventional aircraft the rudder is just a single control surface, which is hinged to the trailing edge of the fin, where its leverage about the centre of gravity is at its greatest. The pilot’s feet rest on the rudder pedals during normal flight. To yaw to the left, the pilot pushes the left pedal forward, which makes the rudder move out to the left. The rudder is now out of alignment with the fin and at an angle of attack to the airflow. This produces a sideways force to the right, through the rudder hinge onto the tail.

Fig 3-11 Position of the rudder

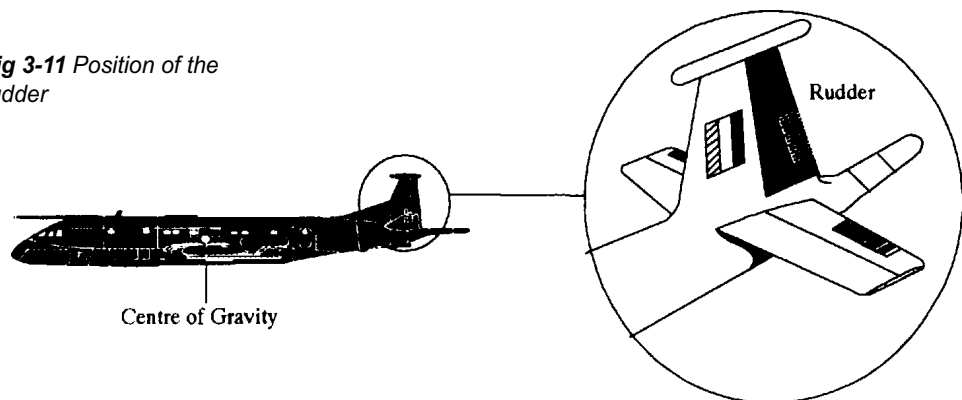

The tail is pushed sideways to the right, and the nose, of course to the left: the aircraft is now yawing to the left about its normal axis. The yawing ceases when the pilot centralises the rudder pedal so that the rudder again lies in line with the fin. Yaw to the right is obtained by pushing the right rudder pedal forward. As with other control movements, always remember that the aircraft will yaw whatever its initial attitude may be. “Left rudder, yaw to the left”, “Right rudder, yaw to the right”. All the diagrams in this chapter show large movements of the control surfaces for the sake of clarity, but in actual flight, very small angular movements are needed to produce the desired effects of pitching, rolling and yawing.

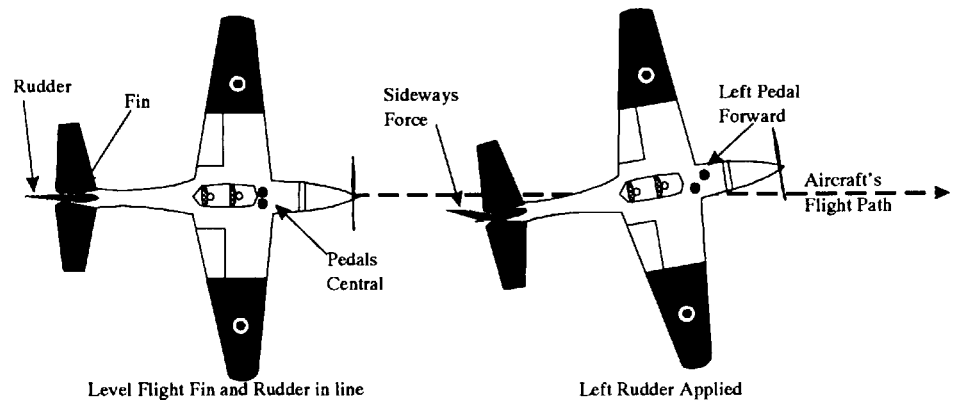

Fig 3-12 Effect of the rudder

Trimming Tabs, Flaps And Slats

What is trimming?

10. The weight and the position of an aircraft's centre of gravity can change in flight, when fuel is used up, bombs dropped, ammunition fired and so on.

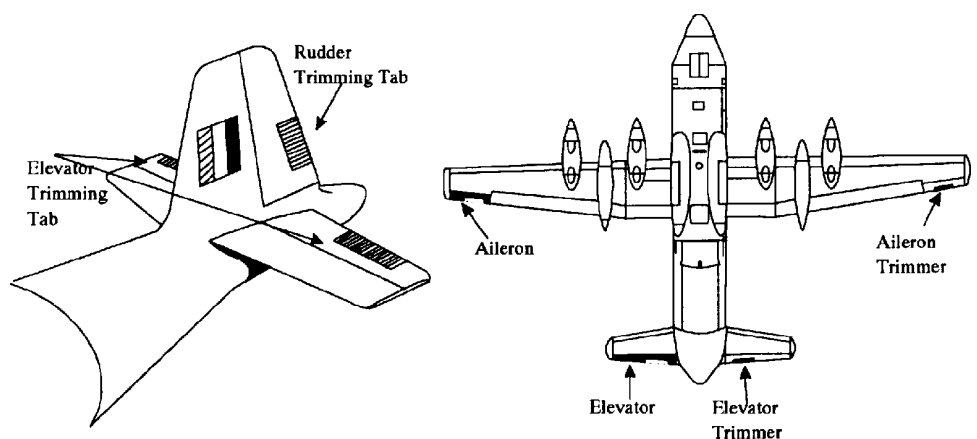

Fig 3-13 Location of trimming tabs

The centre of pressure will also change during the flight - usually with alterations of power, speed or attitude. All such changes will affect the balance of forces on the aircraft, sometimes quite markedly. For example a sideways pressure on the stick would be needed to keep the aircraft balanced if fuel is used from the left wing tank quicker than from the one on the right, making the aircraft right-wing heavy. Or on a multi-engined aircraft, should one engine fail or lose power, the differential thrust on the two wings would produce a yawing force which would have to be opposed by constant pressure on a rudder pedal, to maintain direction. In all these conditions, no pilot could fly accurately and safely for long without some help.

Controllable Trimming Tabs

Where are Trimming Tabs?

11. In fact the help provided on most aircraft comes in the form of “trimming tabs”, which can be used to “trim out” (or cancel out) the forces on the stick or rudder. They are hinged to the trailing edges of the elevators, ailerons and rudder, and can be moved at an angle to those surfaces by separate controls in the cockpit. Suppose that an aircraft has become nose-heavy and the pilot has to maintain a steady backward pressure on the stick; the pilot is all the time holding the elevators up at a slight angle, as in the diagram (b) below. To trim out the constant backward force on the stick, the pilot operates the elevator trim control in the cockpit so as to depress the elevator trimming tabs downward into the airflow.

Use of Trimming Tabs

(a) Elevator trimming tab in-line with elevator. Aircraft balanced.

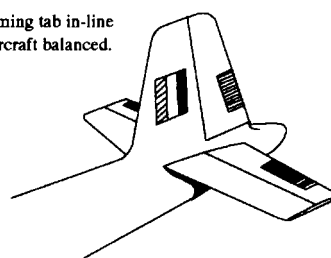

(b) Aircraft becomes nose-heavy. Pilot pulling back on stick.

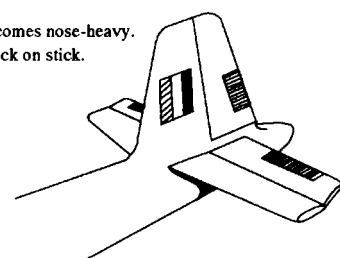

(c) Elevator trimming tab down a little. Pilot pulling back on stick - but less than before.

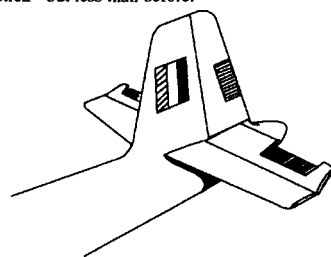

(d) Elevator trimming tab down still more. Correct position found. Aircraft flies "Hands off".

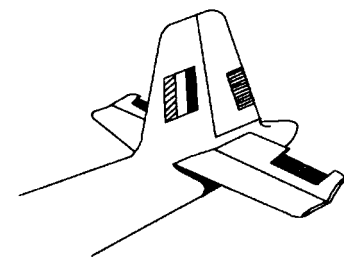

Fig 3-14 Using the elevators trimming tabs

As the tabs are now at an angle of attack to the airflow, they produce lift which helps to hold the elevator up at the required angle (c). Finally the pilot adjusts the elevator trimming tabs until they are exerting enough force to remove entirely the need to hold a pressure on the control column. The airflow on the elevator trimming tabs is producing the necessary upward force on the elevator. The aircraft is said to be trimmed longitudinally and will fly “hands off” (d). Aileron and rudder trimming tabs operate on the same principle.

Flaps

Location of flaps

12. For the sake of safety, an aircraft’s wing should be designed so that the aircraft can make its approach to land at a controlled slow speed, and along a moderately steep approach path (so the pilot can see easily over the nose, to where the aircraft is landing).

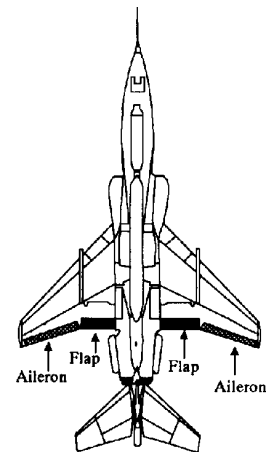

Fig 3-15 Location of flaps

However, this design of wing will not be efficient at the higher speeds needed for transit and other operational flying. A well-proven solution to the problem is to design the wing largely for its main task, and to add flaps for use on the approach and landing.

Operation

How do flaps work?

13. The flaps are hinged surfaces, usually fitted to the trailing edges of the wings, inboard of the ailerons. They can be mounted along the leading edges - and some aircraft, particularly airliners, have them at both the leading and trailing edges. However, we shall confine ourselves to the trailing edge variety. The flaps, one on each wing, are operated together and in stages by the pilot. In the unused or “up”

position they lie flush with the wing surfaces and form part of the wing, and in the fully “down” position they are at an angle of 90° or so to the wing surfaces.

14. There are many types of flaps, each with their own characteristics, but when selected down they all increase the effective camber of the wing and hence its lift. In addition, flaps will increase drag. Examples of different types of flaps are shown in the diagram. For most flaps, there is a huge gain in lift when they are lowered to angles of 30° to 60° , and very little more at 60° to 90° . Drag, on the other hand, increases only moderately at small angles and greatly at large angles of depression.

Types of flaps

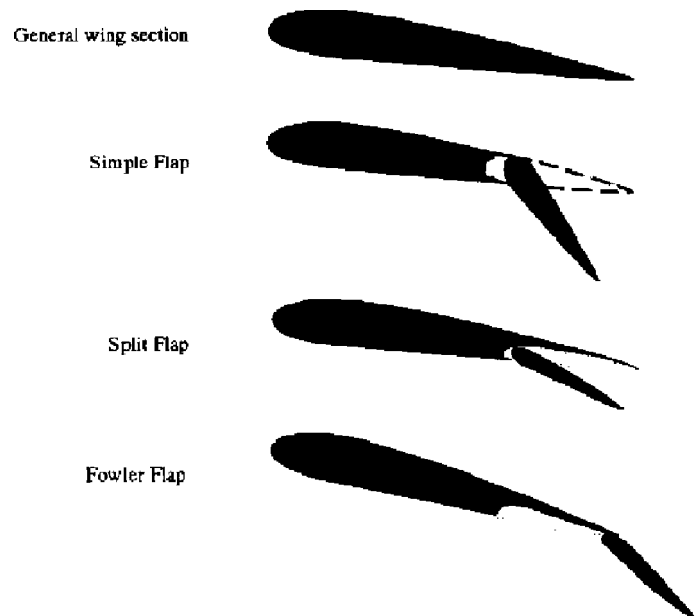

Fig 3-16 Some types of flaps

Obviously, because of the greatly increased lift given at 30° of flap, the stalling speed is reduced and consequently it is possible to use slower, safer approach and landing speeds. However, because very little extra drag is being produced, the approach angle is scarcely affected.

15. If 90° of flap are selected however, this gives a tremendous increase in drag, which in turn means that the pilot must lower the nose considerably to maintain the approach speed - in other words, the pilot has a much steeper approach angle and therefore a better forward view. Advantages of the lower approach speed include a reduced touch-down speed and a shorter landing run. Finally, the use of a small amount of flap (about 15°) will also improve the lift at take-off speeds, with such a small penalty in drag, that for most aircraft types a shortened take-off run is possible.

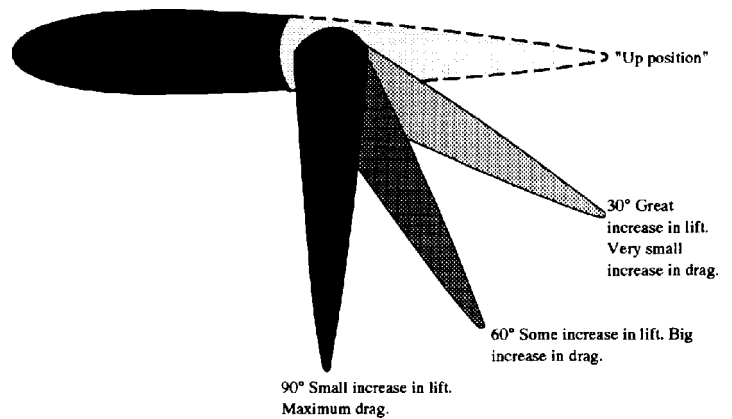

Fig 3-17 Flap positions

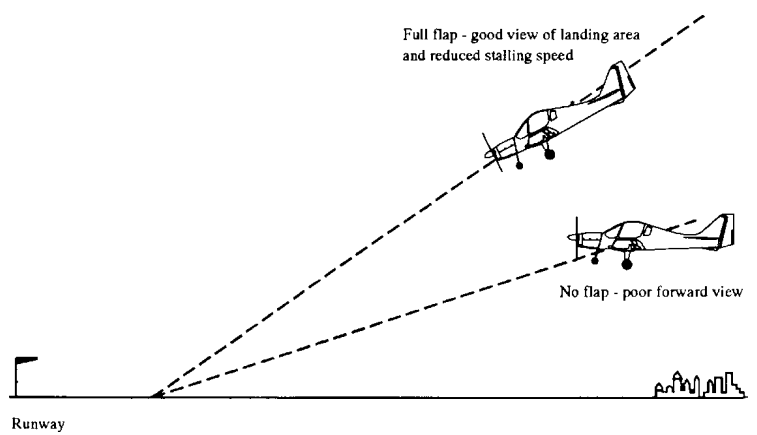

Fig 3-18 Use of flap on the approach

Slats

What is a slat?

16. Slats are another device which designers may fit to improve handling at low speeds. They are small aerofoils (i.e. shaped so as to develop lift), positioned along the leading edge of each wing. The diagram shows an automatic slat, which is designed so that when it is not needed it is held in the closed position by springs.

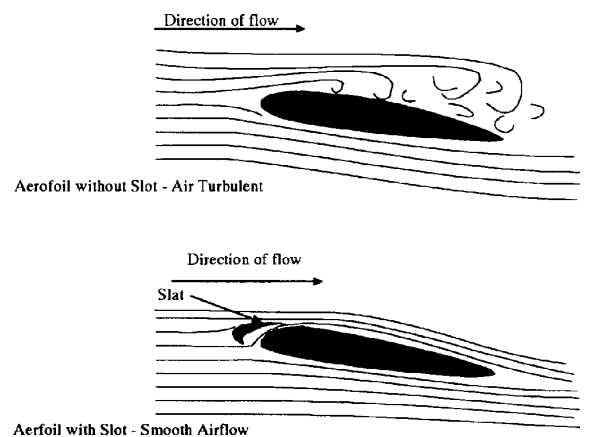
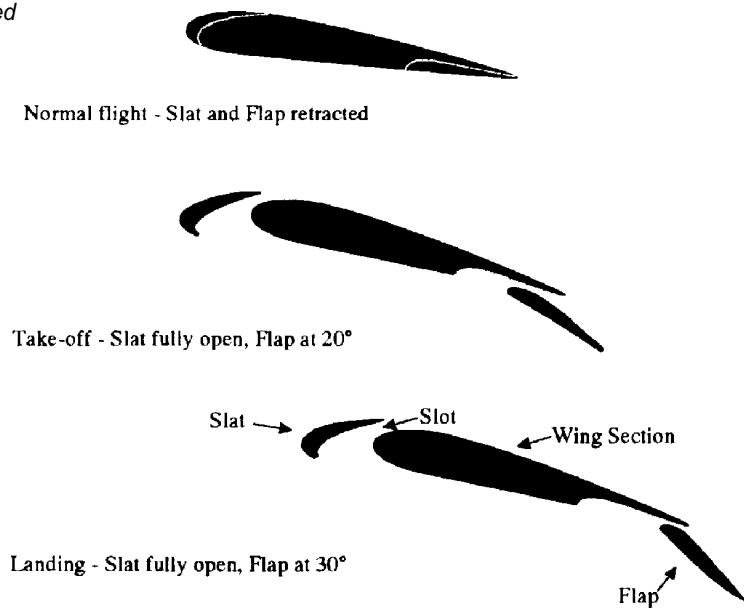

Fig 3-19 Effects of slot on airflow

Advantages of slats

When the wing reaches a high angle of attack, the lift forces on the highly-cambered slat overcome the springs and the slat opens. Air can now flow through the slot formed between the slat and the wing. The shape of the slot is such that the air accelerates through it; this improves the pattern of the airflow over the wing, with some very beneficial effects. Instead of stalling at the usual angle of attack of 15° or so, the wing can reach an angle of as much as 25° before stalling, and the stalling speed is very much reduced. For example, an aircraft whose stalling speed in approach conditions would be 100 kts without slats, might have it reduced to 80 kts with slats fitted. They do, however, cause extra drag which is unwanted at higher operating speeds, which is why they are designed so that the springs close them automatically at lower angles of attack. On some aircraft the slats are not automatic, but are operated from the cockpit in conjunction with the flaps, for use during take-off and landing. To provide maximum lift, so as to take off in the shortest possible distance, the leading edge slats are opened fully, and the flaps are extended to about 20°.

Fig 3-20 Inter-connected slat and flap



When the aircraft is airborne, the slats and flaps are closed and the aircraft is trimmed for normal flight. To provide a steep approach path and slow speed when landing, both slat and flap are fully extended. In the illustration, the amount of flap has been increased to 30°, but this angle varies with different types of aircraft and may be as much as 80°

Self Assessment Questions

Do not mark the paper in any way - write your answers on a separate piece of paper.

1. What are the 3 planes of an aircrafts movement?
 - a. Pitching , lateral and rolling.
 - b. Pitching , rolling and yawing.
 - c. Yawing, longitudinal and rolling.
 - d. Longitudinal, lateral and normal.

2. What are the 3 axes about which an aircraft can move?
 - a. Pitching , lateral and longitudinal.
 - b. Pitching , rolling and yawing.
 - c. Yawing, longitudinal and normal.
 - d. Longitudinal, lateral and normal.

3. Which surfaces control an aircraft in the rolling plane.
 - a. Elevators.
 - b. Ailerons.
 - c. Rudder.
 - d. Tabs.

4. What is indicated by the arrow?
 - a. Elevator.
 - b. Aileron trimming tab.
 - c. Elevator trimming tab.
 - d. Flap.

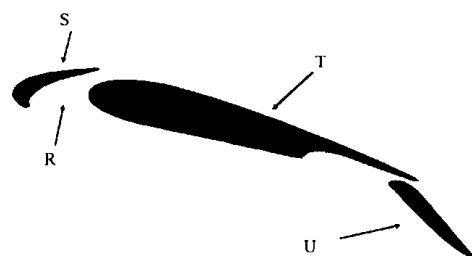
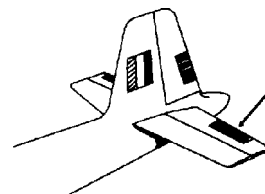

CHAPTER 4

STALLING

Introduction

1. It is vital for a pilot to understand stalling thoroughly, if he is to fly an aircraft confidently at the low speeds required for take-off and landing, or in aerobatics and combat, where high “g” manoeuvres can cause a high-speed stall.

The Stall

The Stall

2. In normal flight a wing meets the oncoming air at a small angle of attack, the air flowing smoothly and continuously over and under the wing. If the pilot increases the angle of attack slightly, the wings will produce more lift - the more the pilot increases the angle of attack, the more lift there will be, until an angle of about 15° is reached. At this point the airflow becomes turbulent, Bernoulli's principle no longer applies and most of the lift is lost - this is the stall.

Stalling Angle

Stalling Angle and Speed

3. This critical angle of attack (the stalling angle) varies from one type of wing to another, as it depends upon the shape and general design of the wing. However, each particular wing has its own stalling angle, and the wing will always stall when the angle of attack reaches that angle. For most conventional aircraft, the stalling angle is around 15°.

Stalling Speed

Pilot's Notes

4. The airspeed at which an aircraft stalls (the stalling speed) does vary. For every type of aircraft there is a booklet called “Pilot's Notes” which gives facts and figures about performance, including the aircraft's various stalling speeds for certain flight conditions. The various factors which affect the stalling speed are:

Factors affecting Stalling Speed

a. Weight. Extra weight (for example, carrying more cargo) increases the stalling speed, and a lower weight (e.g. minimum fuel) reduces it.

b. Power. The higher the power used, the lower the stalling speed. This is because the engine's thrust, although mostly horizontal, has a slight vertical

component which helps the total lift force.

c. Flaps. With flaps lowered (which in effect improves the wing shape for low-speed flight) the stalling speed is reduced.

d. Ice. An accumulation of ice adversely alters the designed shape of the wing section, thereby reducing the lift and increasing the stalling speed.

e. Damaged Wings. Damage to a wing can similarly reduce the lift and so increase the stalling speed.

f. Manoeuvres. Most manoeuvres affect the stalling speed. In a turn the wings are banked, so the lift force is no longer vertical; this means that only a part of it is available to support the weight of the aircraft, so the stalling speed is increased: the steeper the turn, the higher the stalling speed.

Attitude and the Stall

5. It should be stressed that an aircraft can stall in any attitude, whether wings level, in a turn, upside down or whatever. The crucial factor in determining when a wing will stall is the angle of attack.

Self Assessment Questions

Do not mark the paper in any way - write your answers on a separate piece of paper.

1. What happens to lift when a wing is stalled?
 - a. Lift increases as angle of attack decreases.
 - b. Lift decreases as angle of attack increases.
 - c. Lift is lost totally.
 - d. Lift remains unchanged.

2. The critical angle of attack is generally about:
 - a. 5°
 - b. 15°
 - c. 25°
 - d. 35°

3. Which of the following will not reduce the stall speed ?
 - a. Extra weight.
 - b. Larger wing area.
 - c. Flaps lowered
 - d. Flaps raised.

4. Where would you find the information regarding an aircraft's various stalling speeds?
 - a. Pilot's notes.
 - b. Air Traffic Control.
 - c. Ground crew.
 - d. Flying manual.

CHAPTER 5

GLIDING

Introduction

1. You will recall that for a powered aircraft flying straight and level at a constant speed, there are four forces - lift, weight, thrust and drag - in balance. Any alteration to one of these forces will destroy the balance and, depending on which force has been altered, the aircraft will climb, or descend, or accelerate, or decelerate. In particular, if the engine is switched off (ie all thrust is removed), the only way the pilot can maintain a steady airspeed is to pitch the nose down a little and descend. He is now using the pull of gravity - that is, the weight force - to maintain a flying speed sufficient to control and manoeuvre the aircraft. In other words he is gliding. Moreover, if he is in a steady glide (wings level, speed constant), the forces on the aircraft are in balance - even though there is no longer a thrust force. The same applies to a glider.

Balance of Forces

Forces on a Glider

2. The diagram shows a glider in a steady glide, with the 3 forces acting on it. Note the angle the glider is to the horizontal. As we learned earlier, lift acts at 90° to the flight path and drag acts along the flight path; Weight we know acts vertically downwards, towards the Earth.

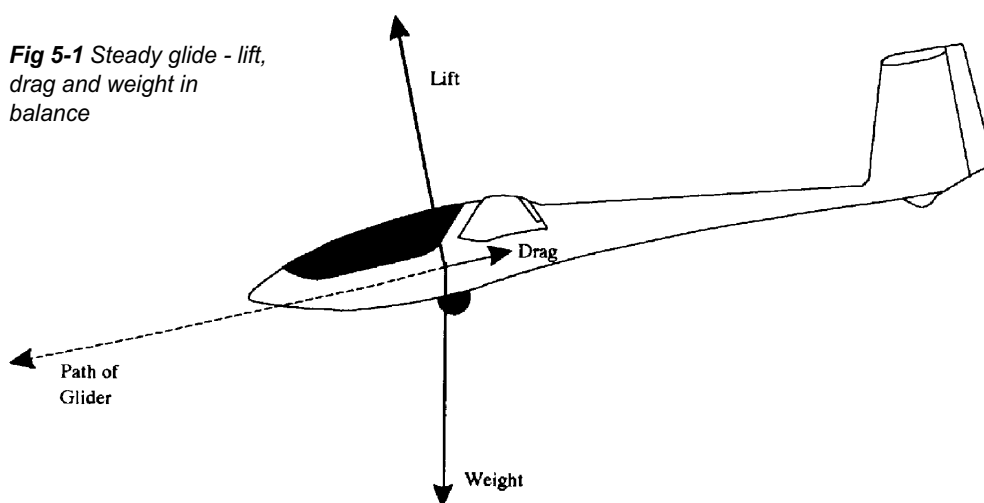

Speed

3. Just as a car can “coast” down hill with its engine switched off, due to the pull of gravity, so can a glider fall, in a controlled way from a set height. As the glider descends, air flows over its wings producing lift. This lift reduces the rate of descent so that the glider can return to the ground safely. If the pilot wishes to increase the airspeed, the nose of the glider is lowered and the aircraft descends faster. Raising the nose reduces the rate of descent and hence the airspeed. Reducing the airspeed too much however, could result in losing so much lift that the aircraft will stall. Since this aircraft has no engine to propel it through the air, in order to maintain steady flight the aircraft must be continually descending.

How Far Will a Glider Travel?

Glide angle

4. The distance a glider will travel over the ground from a given height to ground level, depends upon the gliding angle. The flatter this angle, the further the glider will travel over the ground. It can be shown by geometry that the angle is least when the ratio of lift to drag (the “lift/drag ratio”) is at its highest. This occurs at a certain angle of attack, which will vary from one type of glider to another according to its design. There has to be a way of knowing when the glider is flying at this optimum angle of attack, and fortunately it is related to the airspeed.

Fig 5-2 *Gliding angle and distance covered*

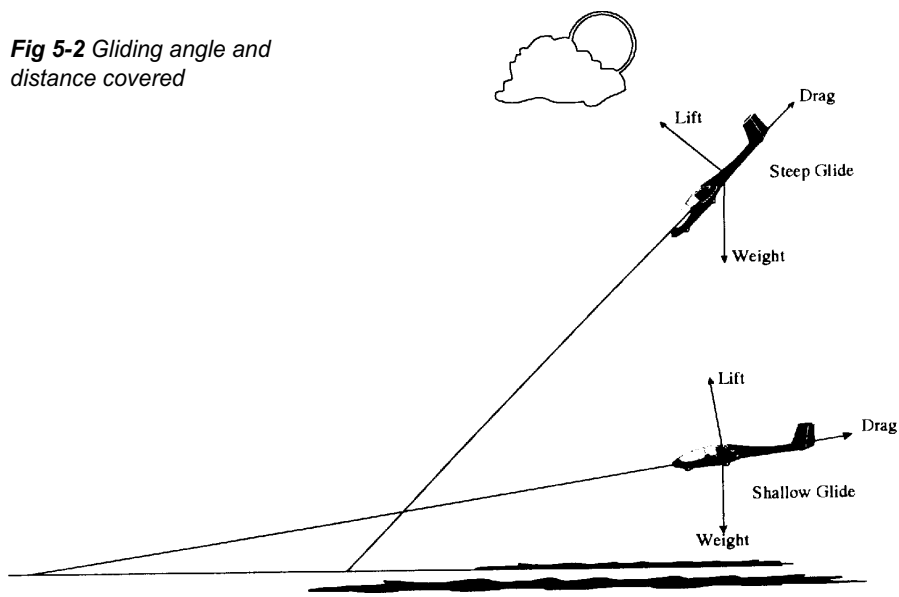

This means that the glider's makers can calculate the required indicated airspeed and state it in the Pilot's Notes. Air Cadet's gliders are modern and efficient, and have a flat gliding angle so that they can go a long way whilst coming down slowly. For the Viking the angle is about 1 in 35, so it follows that from a height of 3,280 feet (one kilometre), in still air conditions the glider will travel 35 kilometres before touching down.

Effect of Wind

Gliders in wind

5. A glider travelling downwind will cover a greater distance over the ground than a glider travelling into wind. The pilot will fly at the same indicated airspeed in both cases, and the glider's angle of attack and its gliding angle relative to the air will be the same in both cases. If you find this difficult to believe, try imagining the glider as flying in a large block of air which is moving in one large piece, high up and well away from the ground and carrying the glider along with it. If you now picture the glider in the same block of air but closer to the ground, you can see that when it is flying into wind the angle of its flight path relative to the ground will be very steep. As an extreme example, a glider with an airspeed of 35 kts, heading directly into a wind of 35 knots would make no forward progress as far as a spectator on the ground was concerned - to the spectator it would simply lose height slowly over one spot on the ground. If the glider then turned until the wind was directly behind it, the spectator would see it covering the ground at nearly 70 knots!

Airbrakes

Airbrakes increase the glide angle

6. Most gliders do not have flaps, but instead are generally fitted with airbrakes. They are panels which normally lie within the wings, with their edges flush with the surface. From a control in the cockpit, the pilot makes them pop out of the upper and lower wings at 90° to the surfaces, where they interfere with the smooth airflow, increasing the drag considerably. To maintain the airspeed the pilot now lowers the nose - which increases the gliding angle, and allows the pilot to land in a smaller space than would otherwise be possible.

Self Assessment Questions

Do not mark the paper in any way - write your answers on a separate piece of paper.

1. Name the 3 forces acting on a glider in normal flight.
 - a. Force, Weight and Lift.
 - b. Drag, Weight and Thrust.
 - c. Drag, Weight and Lift.
 - d. Drag, Thrust and Lift.

2. How does a glider pilot increase the airspeed of the aircraft?
 - a. Operate the airbrakes.
 - b. Lower the nose by pushing the stick forward.
 - c. Raise the nose by pulling the stick back.
 - d. Lower the nose by pulling the stick back.

3. A Viking glider with a glide angle of 1 in 35 is in still air and flying over level ground. What distance will the aircraft travel from a height of 1640 feet (0.5 kilometer) before reaching the ground.
 - a. 70 kms.
 - b. 35 kms.
 - c. 17.5 kms.
 - d. 8.75 kms.

CHAPTER 6

THE HELICOPTER

Introduction

How do helicopters fly

1. You have learned how an aircraft derives lift from the flow of air over wings which are fixed to the body of the aircraft - and how this lift depends upon the forward movement of the whole aircraft through the air. We shall now study a type of aircraft which generates lift by rotating its wings - the helicopter.



Fig 6-1 A rotary-wing aircraft with end view of a rotor blade

How a helicopter produces lift

Blades replace wings

2. The main rotor of a helicopter might not look like wings at first sight, but it is. A cross-section of a rotor blade has an airfoil shape, similar to that of a conventional aircraft wing. Therefore, when a rotor blade moves through the air it can be made to generate lift. The helicopter's engine is used to make the blades rotate - that is, move through the air - and this can be done even when the aircraft is stationary. Thus, all that is needed to ensure that the rotor generates enough lift to make the

Rotor Head

Pitch angle

helicopter rise off the ground, is to rotate the wings fast enough and give them an angle of attack to the airflow. The blades of the main rotor are fitted into the hub (or rotor head) so that they can be twisted. That is, the angle between the chord line of the blade's aerofoil section and its plane of rotation (its "pitch angle") can be varied, which alters the angle of attack and allows the pilot to vary the amount of lift. In the diagram (a) shows a helicopter sitting on the ground with the rotor running at full speed, but with the blades at a very small angle of attack.

Fig 6-2 Helicopter's lift against weight to become airborne

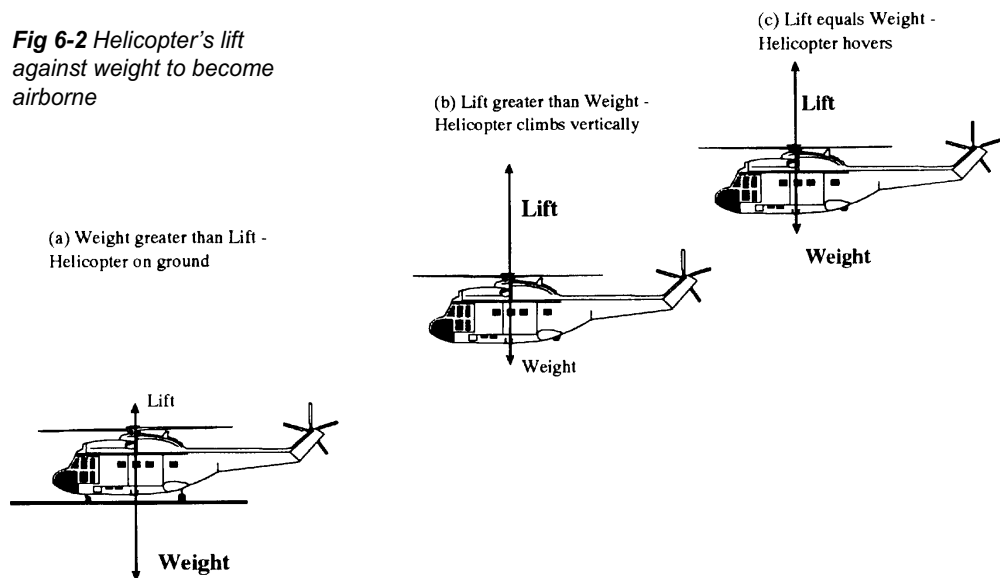

The lift generated is less than the aircraft's weight, and the helicopter stays on the ground. In the diagram (b) the pilot has increased the angle of attack of the main rotor blades and so increased the lift until it exceeds the weight and the aircraft rises vertically. In the diagram (c) the pilot has slightly reduced the angle of attack of the blades so that the lift from the rotor now balances the weight of the helicopter, which now hovers. When the pitch angle of each blade, and hence the angles of attack of all the main rotor blades is altered by the same amount and at the same time, it is known as a "collective" alteration of pitch. The pilot's control which does this is therefore called the collective pitch control.

Horizontal Helicopter Flight

Moving horizontally

The Disc of Rotation

3. To make the aircraft fly forward, horizontal thrust must be available. In a conventional aircraft this thrust is provided by a jet engine or a propeller. In a helicopter it is done by tilting the lift in the direction of the required movements. This is achieved not by tilting the whole of the rotor head, as one might think. Instead, each blade is hinged, and can be made to rise and fall as it goes round the plane of rotation (or “disc”). To make the helicopter go forward, each blade is made to rise as it reaches the rear of the disc, and descend as it reaches the front.

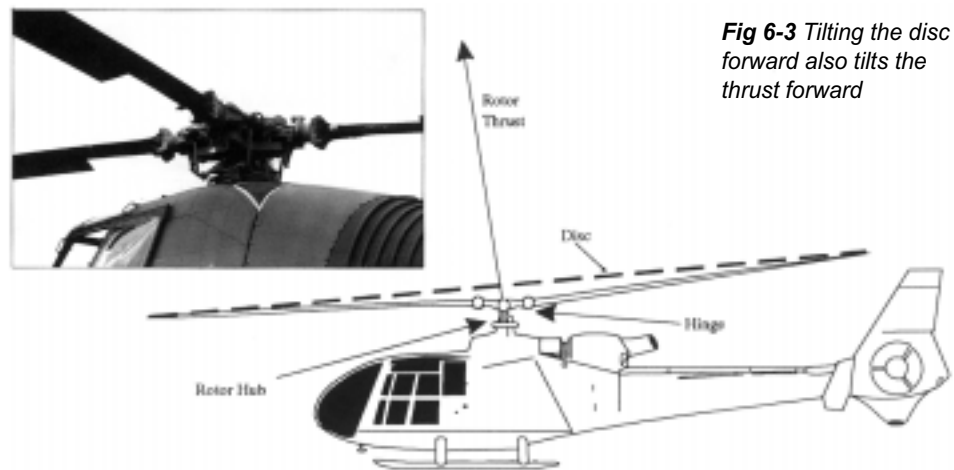

Fig 6-3 Tilting the disc forward also tilts the thrust forward

Thus, the disc is tilted forwards, and there is a horizontal component of thrust to propel the helicopter forwards. Conversely, we could tilt the disc backwards by making each blade rise as it passes over the front and fall as it goes over the rear; the helicopter would move backwards. It could also move sideways by the same principle. The force used to make each blade rise or descend is lift. The pitch angle and hence the angle of attack is increased when the blade is required to rise and decreased for the blade to descend. Obviously, for the rotor disc to stay tilted in the required direction, the pitch of each blade must vary through 360° cycle of travel. Therefore, the pilot's control used for this is called the cyclic pitch control (or cyclic pitch stick).

Torque Reaction

Torque reaction

4. When the engine of a helicopter drives the rotor in its circular motion, there is a tendency for an opposing force (called “torque reaction”) to spin the fuselage of the helicopter the opposite way. The normal solution on a single-rotor helicopter is to fit a small rotor, far back on the tail for leverage, with its rotational disc vertical. Its horizontal thrust force opposes the fuselage torque reaction and permits balanced flight. The pilot can vary the thrust force provided by the tail rotor, to maintain balanced flight or to yaw the aircraft at will (very useful when hovering).

Fig 6-4 Tail rotor balances torque reaction

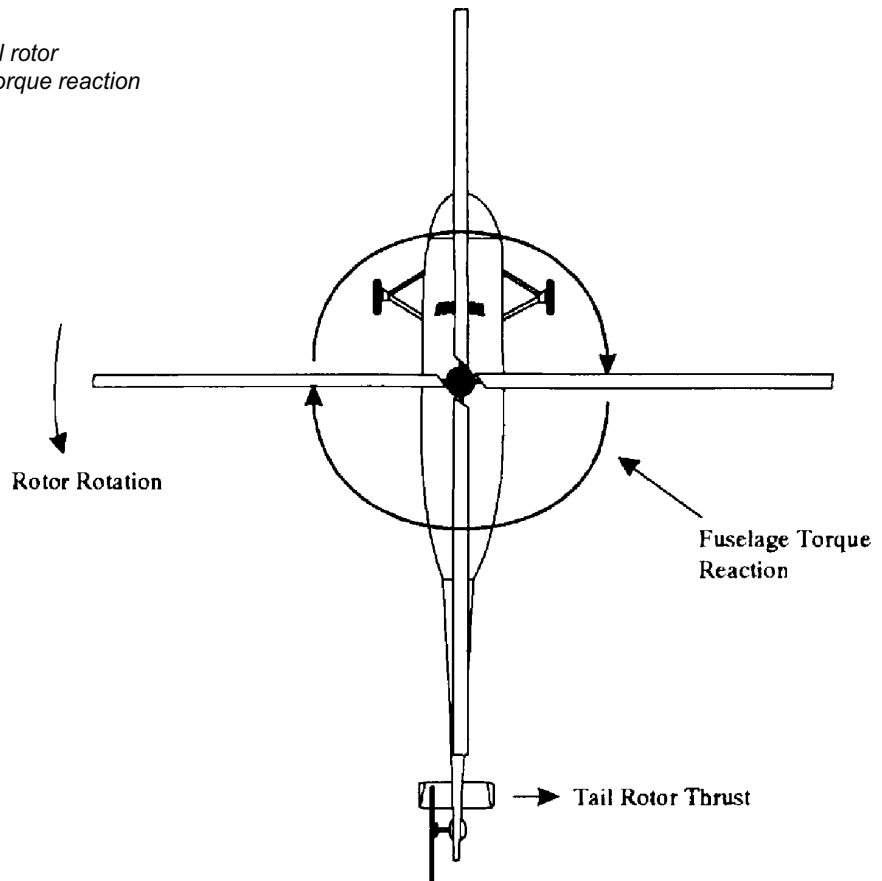

The pilot alters the thrust of the tail rotor by changing the pitch angle and hence the angle of attack of the tail rotor blades, giving more thrust or less thrust or even negative thrust as required. Helicopters with twin main rotors such as the Chinook have each rotor revolving in an opposite direction. The torque reaction from one thus counteracts the other.

Helicopter Controls

5. You now know how a helicopter produces lift and thrust from its main rotor, and how the tail rotor acts as a rudder. As it has no fixed wings or tailplane, the helicopter has no control surfaces (elevators, ailerons, and rudder), and its flying controls operate differently from those of conventional aircraft.

Flying Controls

Helicopter controls

The collective

6. The helicopter has four main flying controls:

a) Collective Pitch Control. The collective pitch control, (or “lever”) which changes the pitch angle of all the blades of the rotor by the same amount at the same time, controls the vertical movement of the helicopter. It is normally on the pilot’s left, for operation by the left hand. The lever is moved up to increase the pitch angle of the blades and down to decrease the angle. When the pitch angle of the blades is increased, the angle of attack and thus the lift will be increased and the helicopter will rise off the ground. However, with increased angle of attack the drag of the blades becomes greater, hence more power is required to keep them rotating at the correct speed. For this reason the lever is attached to a cam arrangement which slightly opens the engine throttle as the lever is moved up, and slightly closes it when the lever is moved down. It works well for small movements of the lever, but something extra is needed for larger movements and the extra device is the hand throttle.

Hand throttle

b) The Hand Throttle. The hand throttle is situated on the end of the collective lever; it is a twist-grip control similar to a motor cycle throttle. The pilot holds the collective pitch control by the twist-grip hand throttle and so can operate both at the same time.

Cyclic pitch control

c) Cyclic Pitch Control. By tilting the rotational disc of the main rotor away from the horizontal, the cyclic pitch control is used to make the aircraft move horizontally. It is normally operated by the pilot’s right hand, and is similar to the fixed wing aircraft’s control column, (or “stick”). If the stick is moved forward, the disc is inclined forward and the helicopter moves into forward flight. The stick can be moved in any direction, tilting the disc in the same direction to move the helicopter forwards, sideways or backwards.

d) Tail Rotor Control. We now have the pilot operating the throttle and collective pitch control with the left hand and the cyclic control with the right hand. This leaves the feet for the tail rotor, which controls the aircraft in yaw (ie directional control). The pilot's feet rest on rudder pedals similar to those of a fixed-wing aircraft. If the left pedal is pushed forward, the nose of the helicopter yaws to the left; right pedal, right yaw. Primarily the purpose of the tail rotor control is to oppose the tendency of the main rotor to make the fuselage rotate - that is, to achieve balanced flight. However, facility to yaw the aircraft (to change the direction in which it is pointing) can be very useful in certain aerobatic manoeuvres and when hovering.



Self Assessment Questions

Do not mark the paper in any way - write your answers on a separate piece of paper.

1. How does a helicopter generate lift?
 - a. Spinning the main rotor faster.
 - b. Spinning the main rotor slower.
 - c. Increasing the angle of attack of each rotor blade.
 - d. Decreasing the angle of attack of each rotor blade.

2. When a helicopter rotor is driven in a circular motion there is an opposing force, what is this force called?
 - a. Lift.
 - b. Torque reaction.
 - c. Lift reaction
 - d. Drag.

3. What is the purpose of a tail rotor?
 - a. Provide thrust.
 - b. Reduce drag.
 - c. Counter torque reaction.
 - d. Control the aircraft in the rolling plane.

4. What are the 3 controls a helicopter pilot uses to control the aircraft attitude?

INSTRUCTORS GUIDE

LIFT AND WEIGHT

Representing Forces

Page 33.2.1-1 Para 2

1. Throughout this volume forces are represented by straight lines drawn in proportion, to show both direction of application and size. Quantitive treatments are not made in any of the examples given - rather, it is expected that cadets receive a general understanding of fundamental principles.

Adding Forces

2. When forces are added together both their size and direction must be considered. Forces can be added to form a RESULTANT so that complicated force diagrams can be simplified. In the diagram below, 2 forces of 4 Newtons(N) and 2N, acting in the same direction and from almost the same point of action, can be replaced completely by the single force of 6N - the Resultant.

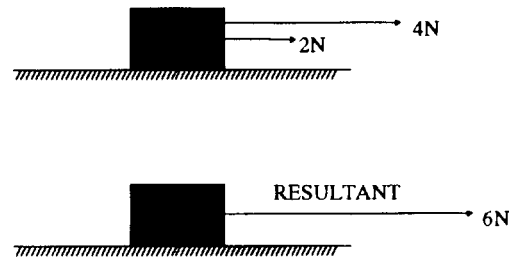

3. The effect of forces in opposition to each other is equally straightforward. Consider an object under the influence of 2 forces of 5N and 2N opposing each other along the same line of action. Clearly the 2 forces could be replaced by a single force of $5N - 2N = 3N$ acting along the same line of action in the direction of the larger force.

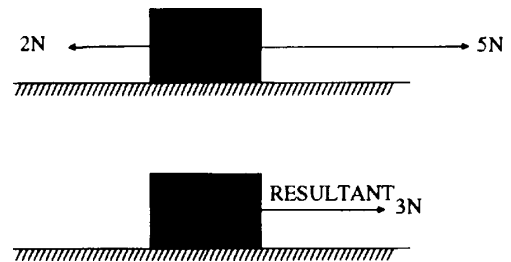

4. In the situation below, 2 forces of equal size act along the same line of action and are in opposition to each other. The resultant force is zero - ie no resultant force exists.

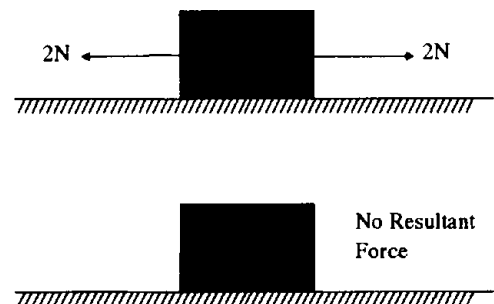

CHAPTER 1

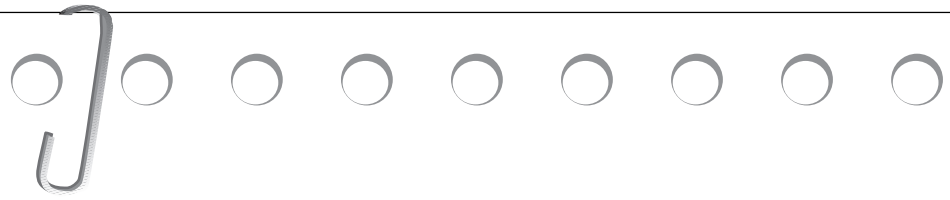
**Page 33.2.1-3 Para 8**MOVEMENT OF FLUIDS

1. A stream or river flows slowly when it runs through open country and faster through narrow openings or restrictions. This is due to the fact that water is practically an incompressible fluid and to keep the rate of flow constant, the water must increase speed in order to pass through a smaller area. Other examples of this are:

Water flowing between large rocks in a stream - if possible demonstrate by floating small sticks.

Slow running water from a tap can be made into a jet by partly covering the opening with a finger.

Page 33.2.1-3 Para 9BERNOULLI'S PRINCIPLE

2. About 1740, Bernoulli obtained a relation between the pressure and velocity at different parts of a moving incompressible fluid - in simple terms, it shows that the pressure is low where the velocity is high; conversely, the pressure is high where the velocity is low.

Examples

3. The canal barges will move together as they pass because the water moving in the narrow space between them speeds up, causing the pressure of the water to drop. Water at a higher pressure on the canal bank side of both barges will move towards the low pressure area - carrying the boats with it.

Other observations

4. A suction effect is experienced by a person standing close to the platform edge at a station when a fast train passes through. The fast moving air between the person and the train produces a decrease in pressure and the excess air pressure behind the person pushes them towards the train.

5. A door left slightly ajar may slam closed in a draught. Moving air is forced through the gap left by the door and as a consequence its speed increases - and its pressure decreases. Surrounding air, at a higher pressure, will push the door closed.

Page 33.2.1-5 Para 13Forces at an angle

If 2 or more forces are acting on a point at different angles to each other, they can still be added together to find their resultant. Consider F_1 and F_2 acting on point) below.

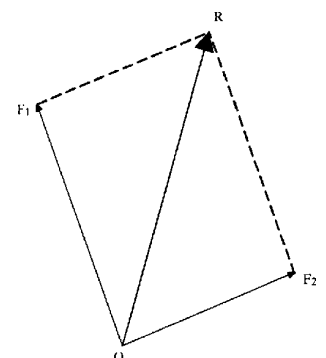

CHAPTER 1



Both of these forces can be replaced by a single force represented in both size and direction by R (the Resultant). To do this we imagine the 2 forces as sides of a parallelogram - complete the figure with guide lines and the resultant is the diagonal!

Centre of Gravity

1. Consider an irregular shaped object as shown in the diagram below. If we imagine the object being made up of many small pieces, each piece will have a weight force acting on it straight down. As we have already seen we can add all these forces together to produce a resultant - but where will the point of action of this resultant be?

2. In a situation as complicated as this, the only easy way to find the point of action of the resultant would be to try to balance the shape, by trial and error. With the shape in balance you would be able to say that the pivot on which the shape balances is directly below the point of action of the resultant force, or total weight. The point where an object's weight appears to act is called its CENTRE of GRAVITY.

***This shape will balance
at the point where the
resultant force acts***

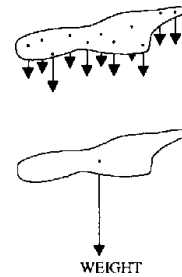

CHAPTER 2



INSTRUCTORS GUIDE

Page 33.2.2-1 Para 4

Pilot's Notes

1. A typical entry in Pilot's Notes may read - The approximate stalling speed for a Bulldog aircraft flying at its maximum permitted weight (2350 lbs) would be:

- a. Power off, flaps up, 53 knots.
- b. Power off, flaps fully down, 50 knots.
- c. Power on, typical approach conditions, 45 knots.

The pilot knows that these airspeeds apply only when the aircraft is not in a turn or indeed in any manoeuvre which imposes a "g" force on the aircraft.

2. Various wings-level manoeuvres will also affect the stalling speed; for example, in a loop the stalling speed at the top (when the aircraft is upside-down) can be below the basic figure, as the effective weight of the aircraft is temporarily below normal. Conversely, in the last quarter of the loop, when the manoeuvre involves changing from vertically downwards to straight and level (the same as "pulling out of" a dive), the effective weight of the aircraft is temporarily increased, hence so is the stalling speed.

CHAPTER 3

INSTRUCTORS GUIDE

Page 33.2.3-1 Para 3

More about Drag

1. There are other types of drag that instructors may wish to discuss with cadets who show a particular interest or flare for the subject.

2. Firstly, to understand drag it helps to divide it into two main types, one of which has nothing to do with the lift-producing task of the wing, and one which arises solely from the production of lift. Imagine an aircraft in flight but not producing lift, for example, flying vertically. The air will still provide resistance - and this drag is called "zero lift drag". The same aircraft flying horizontally at the same airspeed will experience the same zero lift drag, but it will also need to generate lift, which will provide some additional drag called "lift dependent drag". Let us consider zero lift drag first.

Zero Lift Drag

3. Surface friction (also called skin friction) is caused by the roughness of surfaces and the viscosity (stickiness) of air. When air is flowing over the surfaces of skin of an aircraft, the thin layer immediately next to the skin is slowed right down or is even stationary. The thin layer above that one is also slowed down by viscosity, but not as much; the next one above is even less affected and so on until a layer is reached which is totally unaffected. The layers between the skin and this unaffected layer have a collective name, "the boundary layer". Typically, the boundary layer will be around 2 to 6 mm thick, although it can be as thin as a fraction of a millimetre. The thicker the boundary layer, the greater the drag. The amount of drag produced also depends on whether the layers within the boundary layer slide over one another in an orderly motion, in much the same way as the action of a pack of cards thrown along a flat surface (smooth flow), or whether they break up into a multitude of tiny vortices and eddies in which there is no set pattern (turbulent flow). When the flow is turbulent, the thickness of the boundary layer increases and causes much more drag than the smooth flow. The whole surface area of an aircraft in flight has a boundary layer and therefore has surface friction drag, so a designer will obviously try to keep the surface area down. However, there are usually many other requirements in conflict - eg the need for bigger wings to generate lift. There are also some complicated design features which control the boundary layer such as sucking it into the wing through porous skin but for most purposes the common way of reducing surface friction is to have highly polished surfaces and to keep them so during the life of the aircraft.

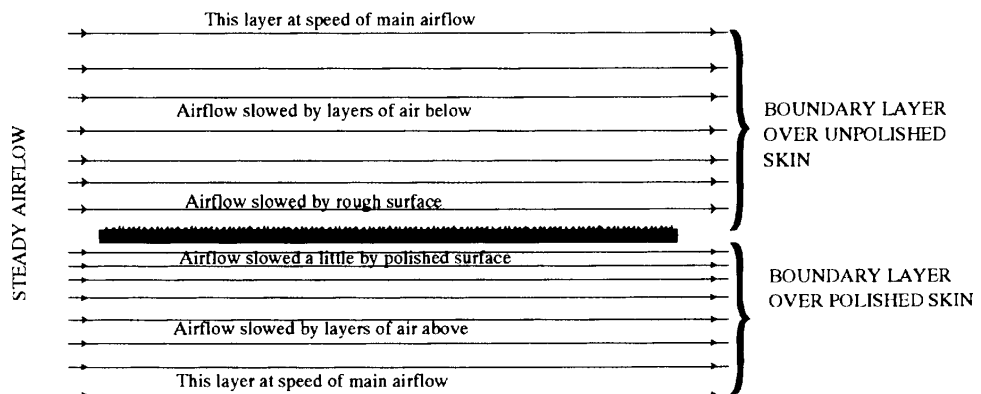

CHAPTER 3

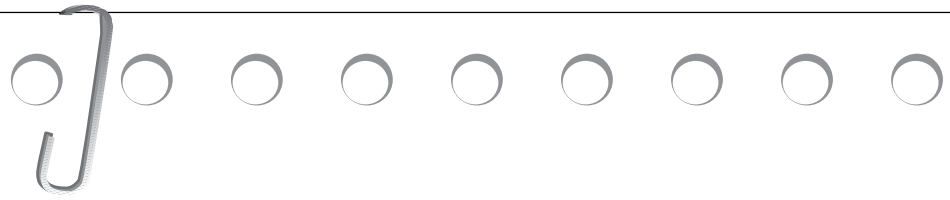

4. Interfering drag is the result of interference between airflows at junctions such as wing/fuselage, engine nacelle/wing, fuselage/fin. Additional eddies and vortices form, and the result is extra drag. Interference drag can be reduced by the addition of fairings at junctions.

Lift Dependent Drag

5. The main component of lift dependent drag is called induced drag. There is another component called "increments of zero lift drag", but it is outside the scope of this publication and we shall not mention it further. Lift dependent drag occurs only when the wings are producing lift and you know that when lift is produced there is low air pressure above the wing and higher pressure below it.

Air flows from HIGH to LOW pressure at the wing tips

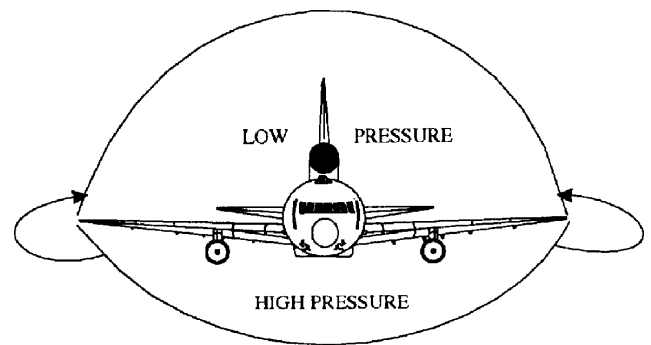

Because air always tends to move between pressure differences (from high to low), and because the high and low pressure regions meet at the wing tips, air will flow from the underside to the topside at the wing tips. This gives the whole of the normal airflow under the wing a slight outwards drift (see below) and it gives that above the wing a slight inwards drift. Combine the two situations and you see that at the trailing edge of the wing, the upper and lower airframes meet each other at a slight angle. Meeting like this causes vortices to form, which takes energy and causes drag.

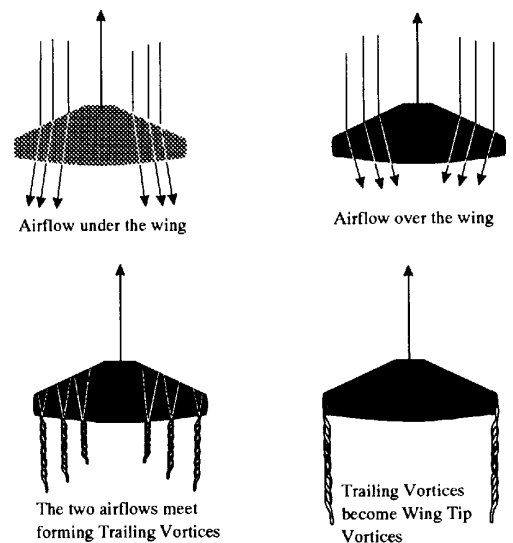

CHAPTER 3

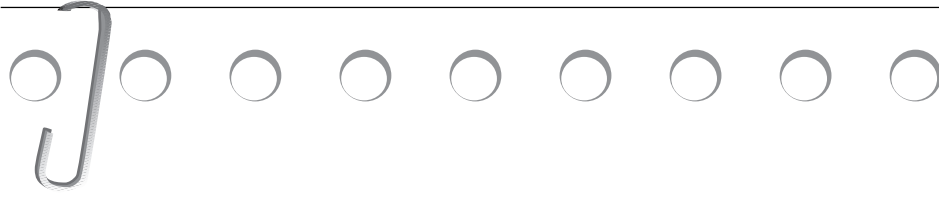

These trailing edge vortices tend to drift towards the wing tip, where they combine to form one large vortex. They are particularly strong in high lift conditions (manoeuvres), when the pressure difference between upper and lower wing surfaces is at its greatest. You might have actually seen wing tip vortices at an air display - the pressure at the core of a vortex can be very low, causing water vapour to condense from the air and show as a trail. Induced drag can be reduced by various design features, all of which are aimed at reducing the spanwise drift of the airflow as it passes over and under the wings, and hence the size of the vortices. They include: wing fences; tapering the wings and changing the section towards the tips; winglets at the tips; and special platforms - examples are elliptical wings, and high aspect ratio wings as used in sailplanes (aspect ratio = span divided by chord).

Variation of Lift Dependent Drag with Airspeed

6. The amount of lift dependent drag varies inversely as the square of the airspeed - that is, at twice the airspeed there is a quarter of the drag; at 3 times the airspeed, one ninth of the drag; and so on.

Page 33.2.3-4 Para 7

FORCES IN ACTION

1. In 1687 Sir Isaac Newton published a work called Principia, in which he developed the laws of mechanics. In his book, Newton formulated three laws of motion which revolutionised our understanding of the way things move. Newton's first law of motion states:

Every body continues in its state of rest or uniform motion in a straight line, unless a force acts on it.

2. In simple terms this means that a force will cause a change in an object's situation - no force = no change. This is particularly important when explaining the situation THRUST = DRAG. When thrust = drag the aircraft has no resultant force acting on it horizontally and so it will continue in its state of uniform motion, neither accelerating nor decelerating - clearly in this particular situation it does not mean a stationary aircraft!

3. When LIFT = WEIGHT however, the aircraft can continue to move with uniform motion (either up or down) or remain at constant height, until the situation changes.

THE AIRCRAFT IN BALANCE

1. You have learned earlier that in straight and level flight, at constant speed, two pairs of forces act on the aircraft. The thrust opposes the drag and is equal to it. The lift equally opposes the weight. However, even though the opposing forces are equal, the aircraft will not necessarily be in balance. It would be ideal if all four forces acted at one central point, as shown in diagram (a). However, in real life they all act in different places, and this can easily upset the aircraft's balance. The weight acts downwards through the centre of gravity of the aircraft, whereas the lift acts upwards through another point, the wing's centre of pressure! The thrust acts along a line running from the tail to the nose of the aircraft i.e. forwards, in line with the propeller shaft or, for a jet engine, the axis of the jet. The total drag acts backwards along a line running from the nose to the tail of the aircraft, parallel to the airflow, but its line of action can be displaced up or down depending upon the design of the aircraft and its flight attitude. A possible (though unlikely) distribution of the 4 forces could be as shown in (b) above. The lift and weight, as they do not act at the same point, exert what is called a "turning moment". That is, they try to turn the aircraft tail over the nose.

CHAPTER 3

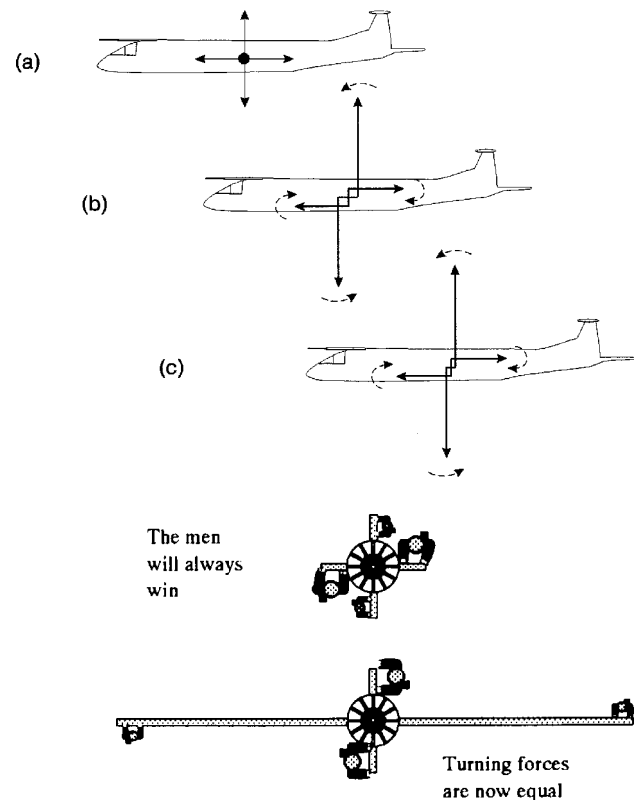
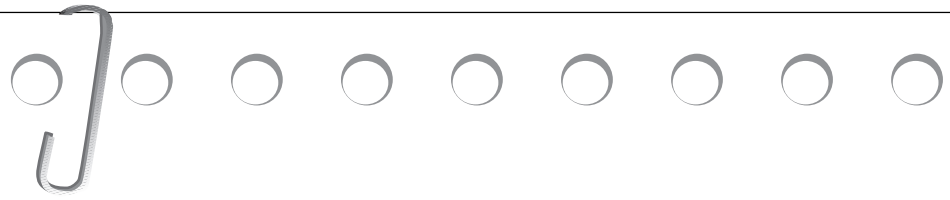

2. The thrust and drag likewise try to turn the aircraft and the weight forces are several times more powerful than the thrust and drag in most aircraft, in diagram (b) above the lift and weight pair would easily win the tussle. The aircraft would be difficult if not impossible to fly - so how can the designer make these two pairs of forces balance? One answer is to give less leverage to the lift and weight pair, by making them act at points much closer together as shown in diagram (c) above. A comparison is given in the diagram opposite. A pair of men who are ten times as strong as a pair of boys oppose them in turning a capstan. The men will win every time if all the capstan levers are of equal length. If the men are given levers ten times shorter than the boys', the forces will balance and the capstan will not turn either way. Other arrangements of the pairs of forces are of course possible, but diagram (c) above is a safe, practical arrangement - for when thrust is reduced or lost (ie when the pilot throttles back, or if the engine fails) the lift/weight pair turn the aircraft nose down towards the gliding angle, which is needed if airspeed is to be maintained and the stall avoided.

Maintaining the Balance

3. The balance of forces required for the normal cruising speed does not necessarily work for other conditions of flight. For example, at a higher cruising speed, the increase in speed will give more lift, hence to stop the aircraft climbing the pilot must reduce the angle of attack of the wings. For reasons which are beyond our scope at this stage, a reduced angle of attack will cause the centre of pressure to move backwards - and in turn this will increase the nose-down turning movement of the lift/weight couple. The balance can also be affected by changes to the weight and centre of gravity which occur as fuel is used up, or when bombs or paratroops are dropped. Bumpy air will temporarily disturb the balance.

CHAPTER 5

INSTRUCTORS GUIDE

RESOLUTION OF FORCES

1. We have previously discussed the advantages of replacing force combinations by single forces (RESULTANTS) in order to simplify force diagrams. In the following example it is necessary to replace a single force with two, so that we can better understand what is happening. This technique is called resolving a force into 2 components.

2. Weight is resolved into 2 components such that W_L is opposite lift and W_D opposite drag. Clearly, the aircraft is in balance, ie UNIFORM MOTION when $W_D = \text{DRAG}$ and $W_L = \text{LIFT}$.

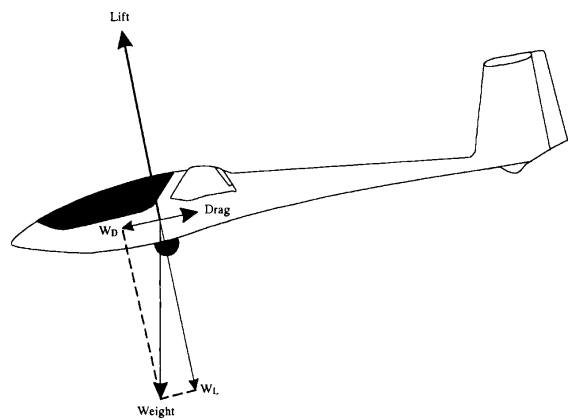

GLIDE ANGLE

3. By lowering the nose of the aircraft, it will be seen that the weight component opposing drag increases significantly, causing the aircraft to accelerate along this line of action until balance is once more restored, ie when $\text{DRAG} = W_D$. The aircraft will now be travelling much faster.

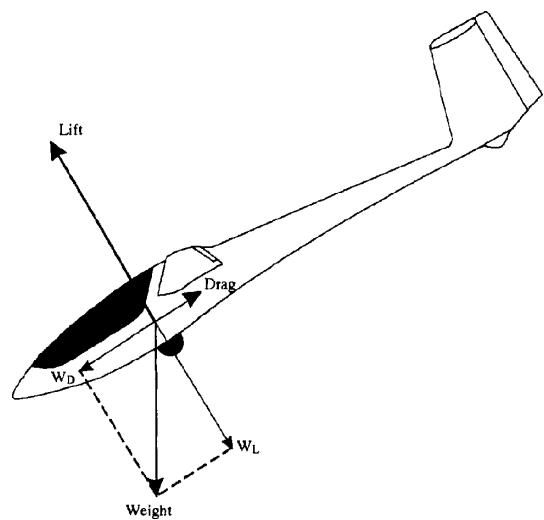

CHAPTER 6

INSTRUCTORS GUIDE

FLAPPING AND DRAG HINGES

1. Horizontal movement is achieved by tilting the rotor disc in a chosen direction. In practice this is achieved by allowing each blade to flap up and down independently. A stop is fitted below each rotor blade to prevent it drooping too far when the rotor is stationary. As the main rotor reaches its normal running speed centripetal force pulls the blades up to their normal operating position - rather like spinning a ball around your head on the end of a piece of string. Each blade can now be twisted or feathered by constantly varying amounts as it travels around the disc, producing different amounts of lift at different positions. The next effect of this is that the rotor disc tilts, producing a horizontal component of lift to move the aircraft horizontally. Resolving lift into 2 components gives:

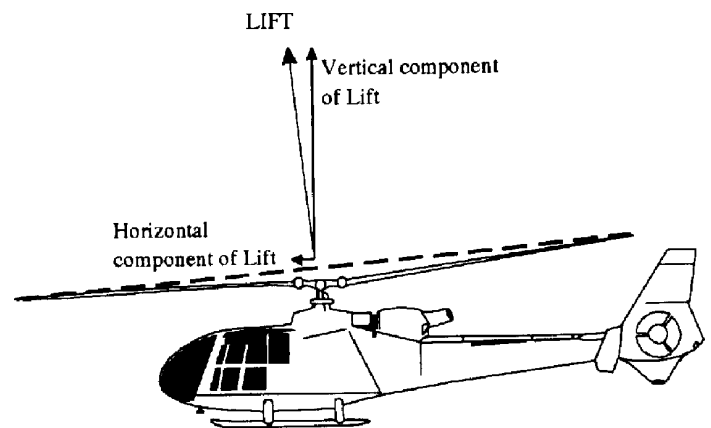

2. There is another reason for having the rotor blades free to flap up and down. When the helicopter is moving forwards, those blades that are rotating forward have a combined airspeed of $\text{SPEED OF ROTATION} + \text{SPEED OF AIRCRAFT}$ (assuming still air). Those blades rotating backwards on the other hand have a combined airspeed of $\text{SPEED OF ROTATION} - \text{SPEED OF AIRCRAFT}$.

3. This difference in speed of airflow over the blades creates different amounts of lift on each side of the aircraft and unless corrected would tend to make the aircraft roll. In practice the blades that are moving forward produce more lift, forcing them to rise on their flapping hinge. Since forward moving blades are now flying higher, their effective angle of attack is reduced - decreasing the lift they produce.



CHAPTER 6

INSTRUCTORS GUIDE

In the same way rearward rotating blades tend to produce less lift causing the blades to fall on their flapping hinge - increasing their effective angle of attack and the lift they produce. The resulting tilting of the disc may be seen when a fast moving helicopter approaches an observer.

4. As well as being free to flap in a vertical plane and to twist on their axes, the blades of most helicopters are free to move in the place of rotation, on drag hinges. This is necessary in order to relieve the bending stresses on the blade roots owing to changes in drag on the blades as they rotate.

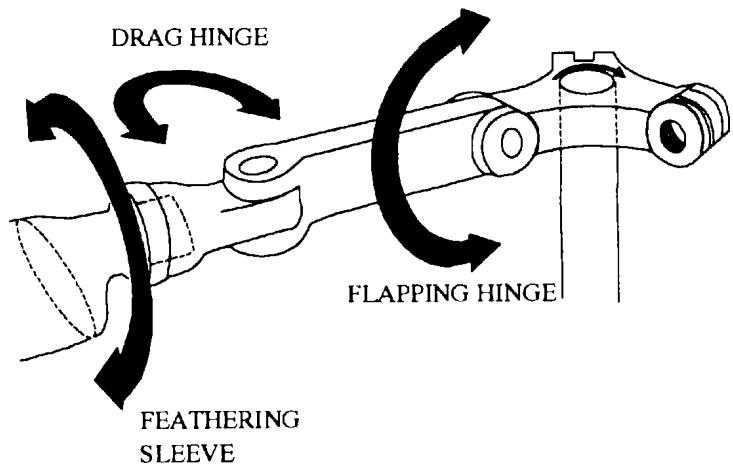

Self Assessment Questions - Answer Sheet

Chapter 1 Page 33.2.1-10

1. a
2. b
3. b
4. b

Chapter 2 Page 33.2.2-3

1. c
2. b
3. d
4. a

Chapter 3 Page 33.2.3-5

1. c
2. d
3. b
4. c

Chapter 4 Page 33.2.4-15

1. b
2. d
3. b
4. c
5. S = Slat R = Slot T = Wing Section U = Flap

Self Assessment Questions - Answer Sheet cont....

Chapter 5 Page 33.2.5-4

1. c
2. b
3. c

Chapter 6 Page 33.2.6-7

1. c
2. b
3. c
4. Collective pitch control
Tail Rotor via your pedals
Cyclic pitch control